



Energy Storage System ATG-ST-H01 Series

ATG-ST-H01-10kW-10kWh
ATG-ST-H01-10kW-15kWh
ATG-ST-H01-12kW-15kWh
ATG-ST-H01-12kW-20kWh

User Manual

Foreword

Summaries

Thank you for choosing the energy storage system ATG-ST-H01 series (hereinafter referred to as ATG-ST-H01)!

This document gives a description of the energy storage system ATG-ST-H01 series, including the features, performance, appearance, structure, working principles, installation, operation and maintenance, etc.

Please save the manual after reading, in order to consult in the future.



NOTE

The figures in this manual are just for reference, for details please see the actual product.

Suitable Model

- Hybrid inverter
 - ATG-I-H01-7.6kW
 - ATG-I-H01-9.6kW
 - ATG-I-H01-10kW
 - ATG-I-H01-11.4kW
 - ATG-I-H01-12kW
- Battery module
 - ATG-B-H01-5kWh









NOTE

The energy storage system ATG-ST-H01 series consists of hybrid inverter and battery module.

Symbol Conventions

The manual quotes the safety symbols, these symbols used to prompt users to comply with safety matters during installation, operation and maintenance. Safety symbol meaning as follows.

Symbol	Description
	Alerts you to a high risk hazard that will, if not avoided, result in serious injury or death.
	Alerts you to a medium low risk hazard that could, if not avoided, result in moderate or minor injury.
	Alerts you to a low risk hazard that could, if not avoided, result in minor injury.
	Anti-static prompting.
	Be care electric shock prompting.
	Provides a tip that may help you solve a problem or save time.
	Provides additional information to emphasize or supplement important points in the main text.

Contents

1 Safety Description.....	1
1.1 Safety Announcements.....	1
1.1.1 Use Announcements.....	1
1.2 Safety Precaution for Hybrid Inverter.....	3
1.2.1 Hybrid Inverter Symbol Illustration.....	3
1.2.2 Protection for PV Array.....	4
1.2.3 ESD Protection.....	4
1.2.4 Grounding Requirements.....	4
1.2.5 Moisture-proof Protection.....	5
1.3 Safety Precaution for Battery module.....	5
1.3.1 Battery Module Symbol Illustration.....	5
1.3.2 General Safety Precautions.....	6
1.3.3 Response to Emergency Situations.....	6
1.4 Safety Warning Label Setting.....	7
1.5 Electrical Connection Requirements.....	8
1.6 Measurement Under Operation Requirements.....	8
1.7 Operator Requirements.....	9
1.8 Environment Requirements.....	9
2 Overview.....	10
2.1 Product Intro.....	10
2.1.1 Model Meaning.....	10
2.2 Appearance and Structure.....	11
2.2.1 Appearance.....	11
2.2.2 Dimension.....	12

2.2.3 Ventilation Design.....	12
2.2.4 LED Signals.....	13
2.2.5 Structure Layout Illustration	14
2.3 Application Scenarios.....	16
3 Installation.....	17
3.1 Installation Process.....	17
3.2 Installation Preparation	18
3.2.1 Tools.....	18
3.2.2 Installation Environment.....	19
3.2.3 Installation Space	19
3.3 Transportation and Unpacking	20
3.3.1 Transportation	20
3.3.2 Unpacking and Checking	21
3.4 Battery Module Configuration	24
3.5 System Diagram	25
3.6 Mechanical Installation	25
3.7 Electrical Connection	32
3.7.2 Connecting Materials Preparing.....	33
3.7.3 DC Input (PV) wires and Grounding wire Connection	35
3.7.4 External RSD button connection.....	37
3.7.5 AC wires, Grounding wire and Signal wires Connection.....	38
3.7.6 Meter connection and setting (Optional)	42
3.7.7 CT connection (Optional)	43
3.7.8 Generator signal connection (Optional)	44
3.7.9 WIFI Communication Connection	44
3.7.10 Battery Module Connection	46
3.8 Install Side Cover Panel	47
3.9 Check the Installation.....	48
4 APP Operation.....	50
4.1 First Startup.....	50

4.2 Information Query.....	57
4.3 Running Data	59
4.3.1 Running Data	59
4.3.2 Status Data	62
4.4 Indicator light and Alarm query	63
4.5 Device Control	64
4.5.1 Grid Setting.....	65
4.5.2 Basic Setting	66
4.5.3 Battery Setting	67
4.5.4 System Setting	68
4.5.5 Schedule Setting.....	68
4.6 Generation statistics	70
4.7 Battery Info	72
4.8 Self-consumption	73
4.9 Work mode	73
4.9.2 Limit grid import function setting.....	76
4.9.3 External control mode function setting	77
4.9.4 "Weather mode" function setting	78
4.10 Zero-Export Function.....	79
4.11 Battery protection	80
4.12 ON/OFF	80
4.13 Agent Configuration.....	81
4.13.1 Agent Management	81
4.13.2 General function configuration	81
4.13.3 Gen. Function (Solar Inverter Access) Configuration	82
4.14 Gen. Function (Generator Access) Configuration	84
4.15 Distribution Box Configuration.....	85
5 Startup and Shutdown	86
5.1 Startup	86
5.2 Shutdown	87

6 Maintenance and Troubleshooting	88
6.1 Maintenance	88
6.2 Troubleshooting.....	90
7 Package, Transportation and Storage.....	99
7.1 Package	99
7.2 Transportation	99
7.3 Storage	99
A Technical Specifications	101
B System Diagram.....	112

1 Safety Description

This chapter mainly introduces the safety announcements. Prior to performing any work on the device, please read the user manual carefully, follow the operation and installation instructions and observe all danger, warning and safety information.

1.1 Safety Announcements



Before operation, please read the announcements and operation instructions in this section carefully to avoid accident.

The promptings in the user manual, such as "Danger", "Warning", "Caution", etc. don't include all safety announcements. They are just only the supplement of safety announcements when operation.



Any device damage caused by violating the general safety operation requirements or safety standards of design, production, and usage will be out of ATG's guarantee range.

1.1.1 Use Announcements



Don't touch terminals or conductors that connected with grid to avoid lethal risk!

 **DANGER**

There is no operational part inside the hybrid inverter. Please do not open the crust of the hybrid inverter by yourself, or it may cause electric shock. The hybrid inverter damage caused by illegal operation is out of the guarantee range.

 **DANGER**

Damaged device or device fault may cause electric shock or fire!

- Before operation, please check if the hybrid inverter is damaged or has other danger.
 - Check if the external device or circuit connection is safe.
-

 **DANGER**

Before checking or maintenance, if the DC side and AC side is power down just now, it is necessary to wait for 5 minutes to ensure the inner device is completely discharged, and then the operation can be performed.

 **DANGER**

The surface temperature of the hybrid inverter may reach to 60°C. During running, please don't touch the surface to avoid scald.

 **CAUTION**

No liquid or other objects are allowed to enter the hybrid inverter, or, it may cause energy storage system ATG-ST-H01 series damage.







CAUTION

In case fire, please use dry power fire extinguisher. If using liquid fire extinguisher, it may cause electric shock.

1.2 Safety Precaution for Hybrid Inverter

1.2.1 Hybrid Inverter Symbol Illustration

Table1-1 Hybrid inverter symbol illustration

Symbol	Illustration
	<p>Beware of a danger zone</p> <p>This symbol indicates that the product must be additionally grounded if additional grounding or equipotential bonding is required at the installation site.</p>
	<p>Beware of electrical voltage</p> <p>The product operates at high voltages.</p>
	<p>WEEE designation</p> <p>Do not dispose of the product together with the household waste but in accordance with the disposal regulations for electronic waste applicable at the installation site.</p>
	<p>Observe the documentation.</p>
	<p>FCC marking</p> <p>The product complies with the requirements of the applicable FCC directives.</p>
	<p>Danger to life due to high voltages in the hybrid inverter, observe a waiting time of 5minutes.</p> <p>High voltages that can cause lethal electric shocks are present in the live components of the hybrid inverter.</p> <p>Prior to performing any work on the hybrid inverter, disconnect it from all voltage</p>

Symbol	Illustration
	sources as described in this document.
	Beware of hot surface The product can get hot during operation.

1.2.2 Protection for PV Array

When install PV array in daytime, it necessary to cover the PV array by light-proof material, or the PV array will generate high voltage under sunshine. If touching PV array accidentally, it may cause electric shock or human injury!



There exists dangerous voltage between the positive and negative of PV array!

When installing the device, make sure that the connection between hybrid inverter and PV array has been disconnected completely. And set warning mark in the disconnected position to avoid reconnecting.

1.2.3 ESD Protection



To prevent human electrostatic damaging sensitive components (such as circuit board), make sure that you wear a anti-static wrist strap before touching sensitive components, and the other end is well grounded.

1.2.4 Grounding Requirements



High leakage risk! The hybrid inverter must be grounded before wiring. The grounding terminal must be connected to ground, or, there will be the risk of electric shock when touching the hybrid inverter.

- When installing, the hybrid inverter must be grounded first. When dismantling, the grounding wire must be removed at last.
-

- Don't damage the grounding conductor.
- The device must be connected to protection grounding permanently.
- Before operation, check the electrical connection to ensure the hybrid inverter is grounded reliably.

1.2.5 Moisture-proof Protection



Moisture incursion may cause the hybrid inverter damage!





Observe the following items to ensure the hybrid inverter works normally.



- When the air humidity is more than 95%, don't open the front panel of the hybrid inverter.
- In the wet or damp weather, don't open the front panel of the hybrid inverter to maintain or repair.

1.3 Safety Precaution for Battery module

1.3.1 Battery Module Symbol Illustration

Table1-2 Battery Module symbol illustration

Symbol	Illustration
	<p>Beware of a danger zone</p> <p>This symbol indicates that the product must be additionally grounded if additional grounding or equipotential bonding is required at the installation site.</p>
	<p>Beware of electrical voltage</p> <p>The product operates at high voltages.</p>
	<p>WEEE designation</p> <p>Do not dispose of the product together with the household waste but in accordance with the disposal regulations for electronic waste applicable at the installation site.</p>
	<p>Observe the documentation.</p>

Symbol	Illustration
	<p>Danger to life due to high voltages in the battery module, observe a waiting time of 5minutes.</p> <p>High voltages that can cause lethal electric shocks are present in the live components of the battery module.</p> <p>Prior to performing any work on the battery module, disconnect it from all voltage sources as described in this document.</p>
	<p>Beware of hot surface</p> <p>The product can get hot during operation.</p>

1.3.2 General Safety Precautions

- Overvoltage or wrong wiring can damage the battery module and cause deflagration, which can be extremely dangerous.
- All types of breakdown of the battery module may lead to a leakage of electrolyte or flammable gas.
- Battery module is not user serviceable. High voltage is present in the device.
- Read the label with Warning Symbols and Precautions, which is on the top of the battery module.
- Do not charge or discharge the damaged battery module.
- Do not damage the battery module in such ways as dropping, deforming, impacting, cutting or penetrating with a sharp object. It may cause a leakage of electrolyte or fire.
- Do not expose battery module to open flame.

1.3.3 Response to Emergency Situations

The battery module is a high-voltage system, if it fails, there is a high-voltage risk. ATG company cannot guarantee the absolute safety of the battery module, so you need to pay attention to the following matters:

1. If a user happens to be exposed to internal materials of the battery module cell due to damage on the outer casing, the following actions are recommended.
 - Inhalation

- Leave the contaminated area immediately and seek medical attention.
 - Eye contact
 - Rinse eyes with running water for 15 minutes and seek medical attention.
 - Contact with skin
 - Wash the contacted area with soap thoroughly and seek medical attention.
 - Ingestion
 - Induce vomiting and seek medical attention.
2. If a fire breaks out in the place where the battery module is installed, perform the following countermeasures.
- Fire extinguishing media
 - Respirator is not required during normal operations. Use FM-200 or CO₂ extinguisher for battery module fire. Use an ABC fire extinguisher, if the fire is not from battery module and not spread to it yet.
 - Fire fighting instructions
 - If the battery module is not on fire yet, extinguish the fire before the battery module catches fire.
 - If the battery module is on fire, do not try to extinguish but evacuate people immediately.
 - Effective ways to deal with accidents
 - On land: Place damaged battery module into a segregated place and call local fire department or service engineer.
 - In water: Stay out of the water and don't touch anything if any part of the battery module, hybrid inverter, or wiring is submerged. Do not use submerged battery module again and contact the service engineer.

1.4 Safety Warning Label Setting

In order to avoid accident for unwanted person gets close to the hybrid inverter or makes improper operation, observe the following requirements while installing, maintaining or repairing.

- Set warning marks where the switches are to avoid switching them on improperly.
- Set warning signs or safety warning belt in the operation area, which is to avoid human injury or device damage.

- When the port of battery module and hybrid inverter are not in use, please don't remove the corresponding waterproof cover.

1.5 Electrical Connection Requirements

Electrical connection must be performed according to the description in the user manual and the electrical schematic diagram.

WARNING

The configuration of PV string, grid level, grid frequency, etc. must meet the technical requirements of hybrid inverter.

Grid-tied generation should be allowed by the local power supply department and the related operation should be performed by professionals.

All electrical connection must meet the related local code requirement.

1.6 Measurement Under Operation Requirements

CAUTION

There exists high voltage in the device. If touching device accidentally, it may cause electric shock. So, when perform measurement under operation, it must take protection measure (such as wear insulated gloves, etc.)

The measuring device must meet the following requirements:

- The range and operation requirements of measuring device meet the site requirements.
- The connections for measuring device should be correct and standard to avoid arcing.

1.7 Operator Requirements

 **CAUTION**

The operation and wiring for energy storage system ATG-ST-H01 series should be performed by qualified person, which is to ensure that the electrical connection meets the related standards.

The professional technician must meet the following requirements:

- Be trained strictly and understand all safety announcements and master correct operations.
- Fully familiar with the structure and working principle of the whole system.
- Know well about the related standards of local country and district.

1.8 Environment Requirements

 **CAUTION**

Avoid the energy storage system ATG-ST-H01 series suffering directly sunshine, rain or snow to prolong the service life. If the installation environment does not meet the requirement, the guarantee time may be influenced.

The used environment may influence the service life and reliability of the energy storage system ATG-ST-H01 series. So, please avoid using the hybrid inverter in the following environment for a long time.

- The place where beyond the specification (operating temperature:-20°C~50°C, relative humidity: 0%-100%).
- The place where has vibration or easy impacted.
- The place where has dust, corrosive material, salty or flammable gas.
- The place where without good ventilation or closed.

2 Overview

This chapter mainly introduces the device features, appearance, operating mode, etc.

2.1 Product Intro

With energy storage system ATG-ST-H01 series, it is possible to effectively manage energy in owners' home day and night. This energy storage system will provide a complete energy solution with multiple working modes which meet different application scenarios. It will bring independence and economy for energy use.

2.1.1 Model Meaning

Hybrid inverter

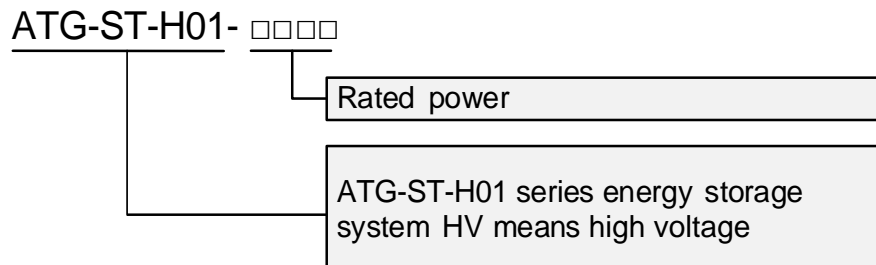

Figure2-1 Model meaning of hybrid inverter

Battery module

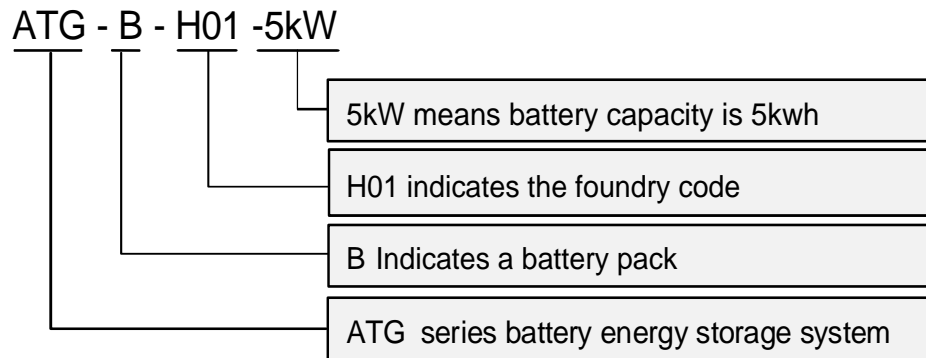

Figure2-2 Model meaning of battery module

2.2 Appearance and Structure

2.2.1 Appearance

The appearance of the hybrid inverter and battery module are as shown in Figure2-3 and Figure2-4.

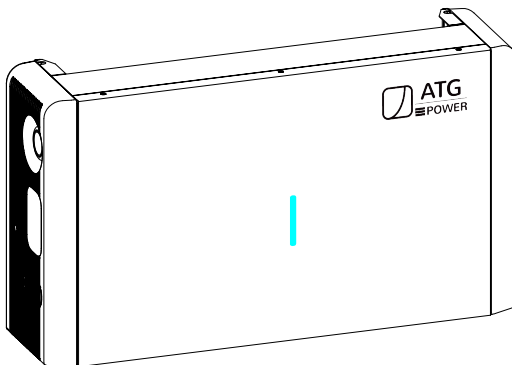

Figure2-3 Appearance of the hybrid inverter

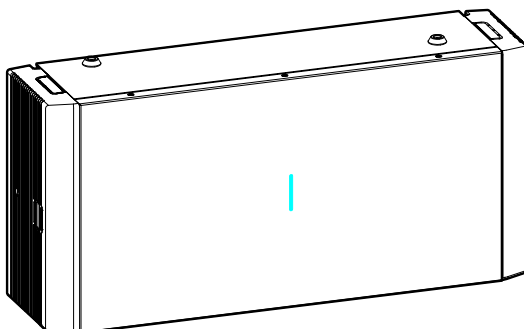

Figure2-4 Appearance of the battery module

2.2.2 Dimension

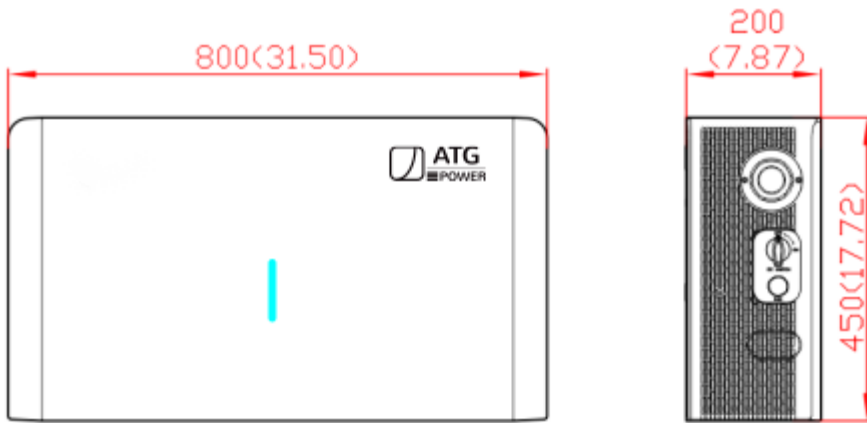

Figure2-5 Hybrid inverter size (unit: mm (in))

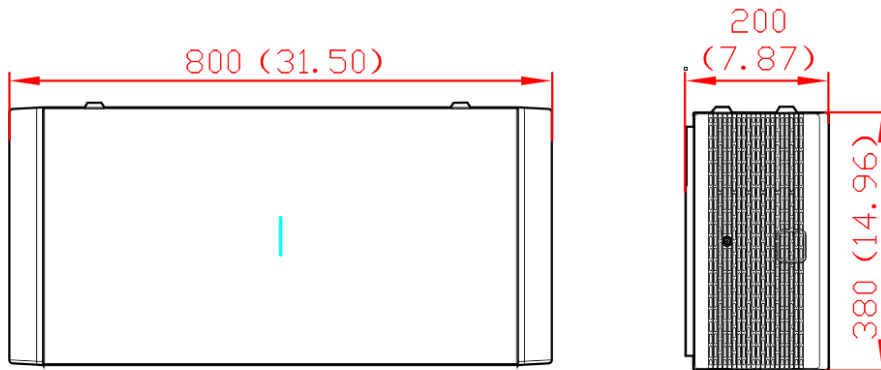

Figure2-6 Battery module size (unit: mm (in))

2.2.3 Ventilation Design

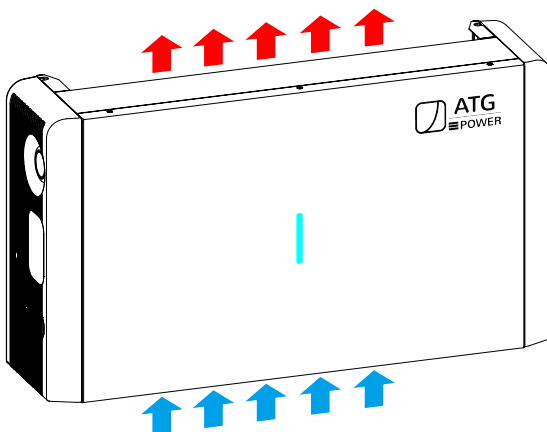

Figure2-7 Hybrid inverter ventilation

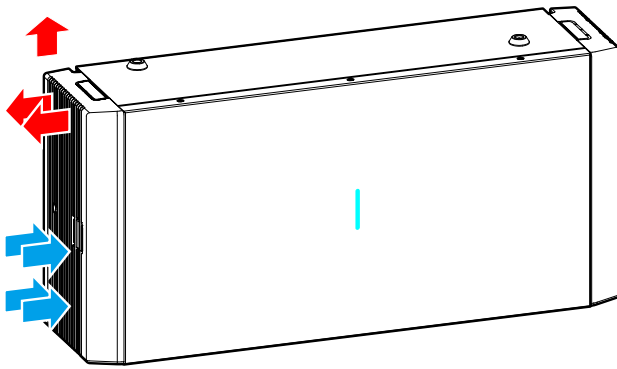

Figure2-8 Battery module ventilation

2.2.4 LED Signals

Hybrid inverter





Table2-1 Illustration of the hybrid inverter LED

LED display	Status	Illustration
	Blue indicator on	Hybrid inverter is running.
	Flickers in blue and red alternately	Hybrid inverter is running and with minor alarm.
	Flickers in blue	Hybrid inverter standby or shutdown.
	Flickers in red	Hybrid inverter standby or shutdown, and With minor alarm.
	Red indicator on	Hybrid inverter abnormal and with major alarm.
	Off	Hybrid inverter is power off.

Battery module

Table2-2 Illustration of the battery module LED

LED display	Status	Illustration
	Blue indicator on	Battery module is running.
	Flickers in blue and	Battery module is running and with

LED display	Status	Illustration
	red alternately	minor alarm.
	Flickers in blue	Battery module standby or shutdown.
	Flickers in red	Battery module standby or shutdown, and With minor alarm.
	Red indicator on	Hybrid inverter/battery module abnormal and with major alarm.
	Off	Battery module is power off.

2.2.5 Structure Layout Illustration

Hybrid Inverter

The external terminals and switch of hybrid inverter are as shown in Figure2-9.

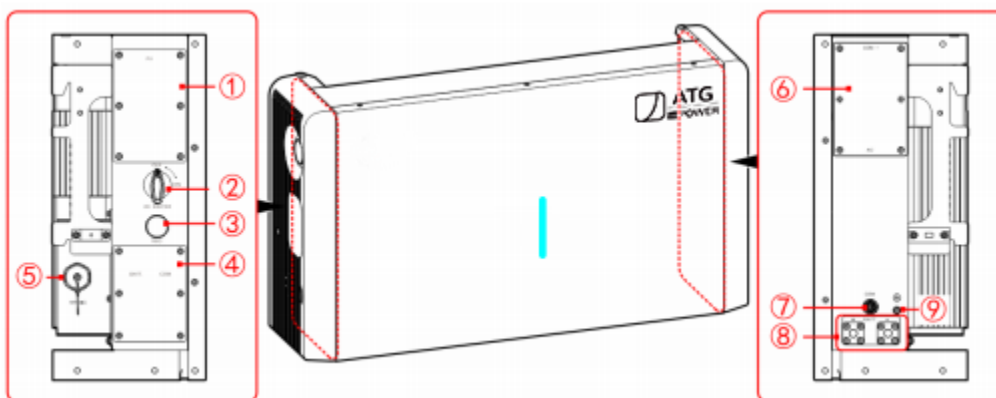



Figure2-9 Hybrid inverter structure layout diagram

Table2-3 Hybrid inverter terminals illustration

No.	Mark	Illustration
①	PV	PV cover plate
②	DC SWITCH	DC switch
③	RSD	Rapid shutdown button
④	BATT., COM	BATT.&COM cover plate

No.	Mark	Illustration
⑤	WIFI/4G	WIFI/4G port
⑥	AC, COM1	AC&COM1 cover plate
⑦	COM	Battery module communication connection port
⑧	BATT.	Battery module DC connection port
⑨		External grounding terminal

Battery module

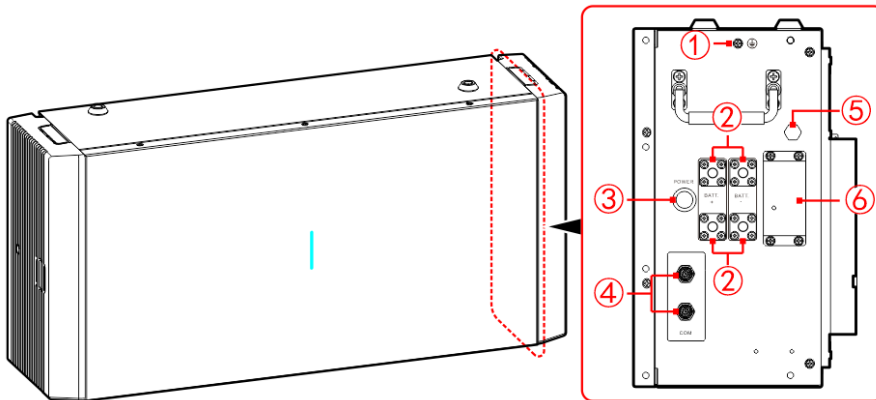



Figure2-10 Battery module structure layout illustration

Table2-4 Battery module structure layout illustration

No.	Mark	Illustration
①		External grounding terminal
②	BATT.+ / BATT.-	Battery module DC communication port
③	POWER	Battery module power button
④	COM	Battery module communication port
⑤	\	Breather valve
⑥	FUSE	Protection fuse

2.3 Application Scenarios

The energy storage system ATG-ST-H01 series can be used in the following scenarios as shown in below.

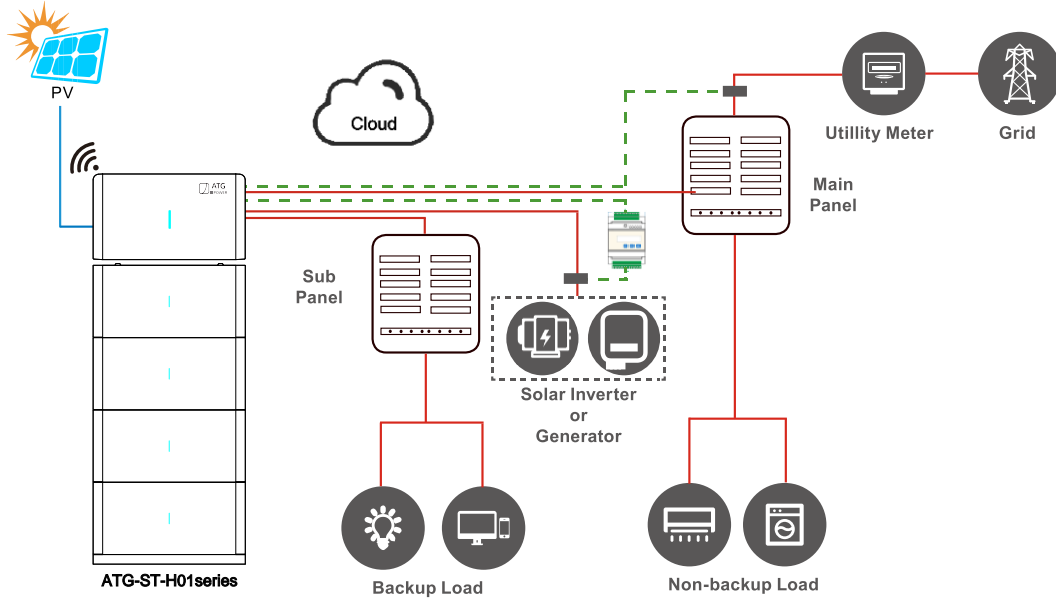

Figure2-11 Partial home load backup system application

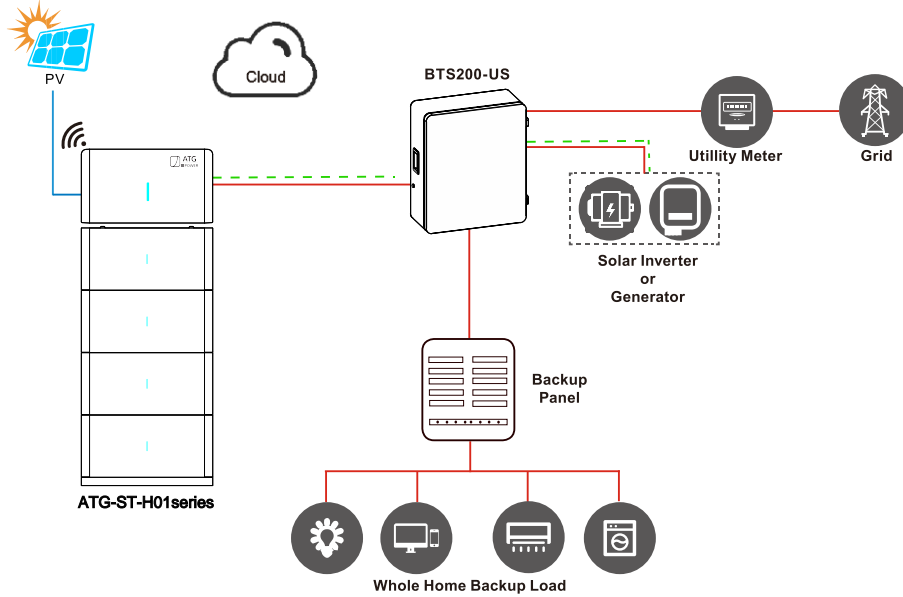

Figure2-12 Whole home load backup system application

3 Installation

3.1 Installation Process

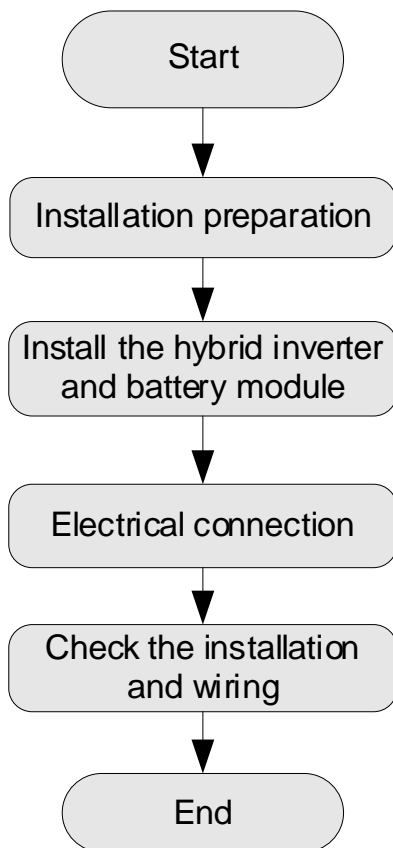
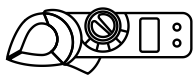
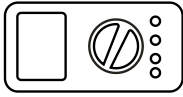
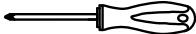

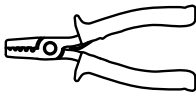
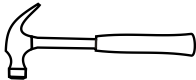
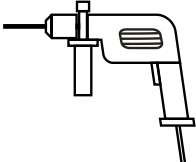
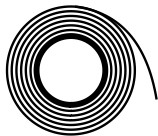
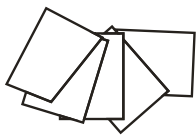
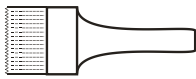
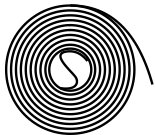
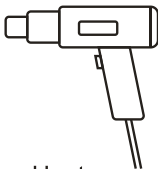

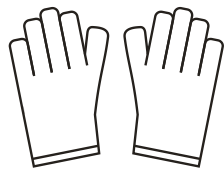
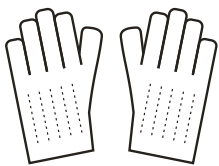
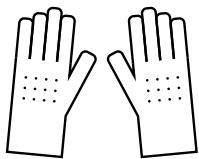

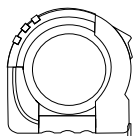

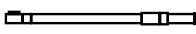

Figure3-1 Installation process

3.2 Installation Preparation

3.2.1 Tools

Tools			
			
Clamp meter	Multi-meter	Label paper	Phillips screwdriver
			
COAX crimping tool	Diagonal pliers	Wire stripper	Claw hammer
			
Hammer drill	Insulation tape	Cotton cloth	Brush
			
Heat shrink tubing	Heat gun	Electrician's knife	Protective gloves
			
ESD gloves	Insulated gloves	Hydraulic pliers	Cable tie
			
Tape	Levelling instrument	Goggles	Torque wrench

⚠ CAUTION

The installation tools must be insulated to avoid electric shock.

When installing, please wear safety gloves and safety shoes.

When installing, please wear safety goggles and a dust mask to prevent dust from entering your eyes.

3.2.2 Installation Environment

- Do not install the ATG-ST-H01 product in the place with poor ventilation.
- Do not install the ATG-ST-H01 product in the place where has flammable or explosive materials.
- Ensure that there has sufficient fresh-air supply around the ATG-ST-H01 product.
- The ATG-ST-H01 product must be installed on the wall or supporter with enough bearing capacity.

📖 NOTE

1. The ATG-ST-H01 product is NEMA 3R for outdoor and indoor installation. But if the ATG-ST-H01 product is installed under directly sunshine, its temperature will rise quickly, so, do not install the ATG-ST-H01 product under directly sunshine.
2. It is suggested to install the ATG-ST-H01 product under shade as shown in Figure3-2 to max the ATG-ST-H01 product lifespan and efficiency.
3. For easy viewing and operating the ATG-ST-H01 product please consider the visibility of the indicators during installation.

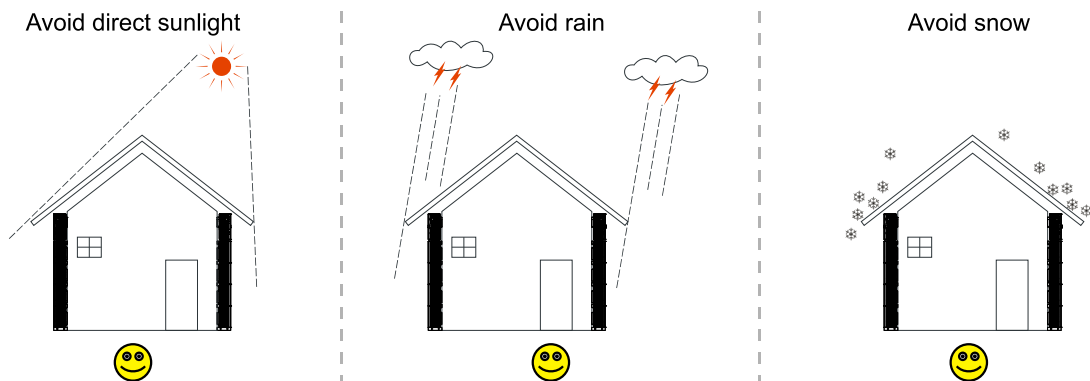

Figure3-2 Recommended installation environment

3.2.3 Installation Space

Keep at least 200mm from the front, left and right side of the device to other objects (such as door, window or other system), keep at least 200mm from the top of the device to ceiling, which are good for heat dissipation, as shown in Figure3-3.

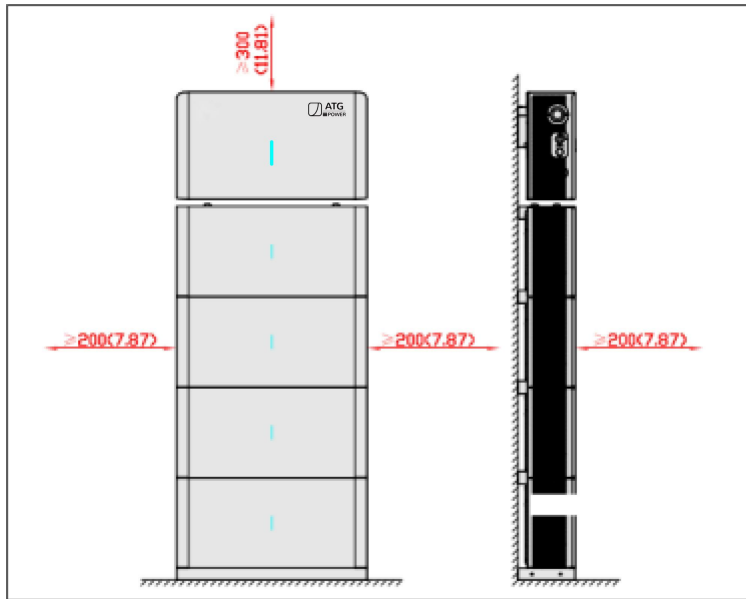

Figure3-3 Installation space (unit: mm (in))

NOTE

The size in above figure is the minimum requirements for heat dissipation, for actual case, please take the space of installation and maintenance into account.

The installation space of energy storage system ATG-ST-H01 series is the same. In above figure, we

take one hybrid inverter and four battery modules as an example to illustrate.

The installation position must meet the local code requirement.

3.3 Transportation and Unpacking

3.3.1 Transportation

The device should be transported by trained professional.



During transporting, please take care and avoid impacting or dropping.

DO NOT reverse place the battery module.

NOTE

We suggest to handle the hybrid inverter or battery module by 2 people at least at the same time, and wear anti-smashing shoes, gloves and other protective equipment.

3.3.2 Unpacking and Checking

 **NOTE**

Select the unpacking site in advance. In principle, the unpacking site should be as close to the installation site as possible.

The device has been tested and checked strictly, but it still may be damaged during transporting, so, please check it carefully.

- Inspect the device's appearance, if any shipping damage is found, report it to the carrier and your local dealer immediately.
- Check if the types of the accessories are complete and correct. If there is any discrepancy, take notes and contact ATG company or local office immediately.

Hybrid Inverter

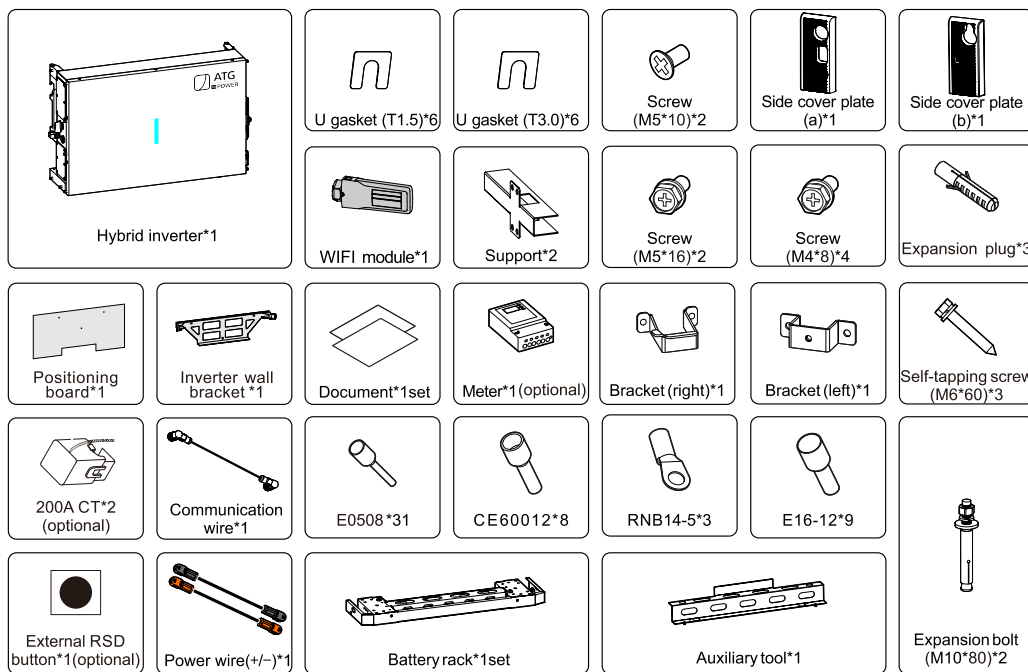

Figure3-4 Hybrid inverter packing list

Table3-1 Hybrid inverter packing list description

Name	Quantity	Illustration
Hybrid inverter	1	Host product
U gasket (T1.5)	6	Adjust the flatness of the mounting accessories and the mounting

Name	Quantity	Illustration
U gasket (T3.0)	6	surface (such as floor and wall).
Screw (M5*10)	2	Fasten the base module.
Side cover plate (a)	1	Left cover plate of the hybrid inverter.
Side cover plate (b)	1	Right cover plate of the hybrid inverter.
WIFI stick	1	The WIFI stick is installed on the WIFI box on the left rear of the hybrid inverter.
Support	2	Installed between the hybrid inverter and battery module, one on the left and one on the right.
Screw (M5*16)	2	Fasten the hybrid inverter to the hybrid inverter wall bracket, one on the left and one on the right.
Screw (M4*8)	4	Fasten the left and right brackets, two screws for each bracket.
Bracket (left)	1	Fasten to the left handle of the hybrid inverter.
Bracket (right)	1	Fasten to the right handle of the hybrid inverter.
Positioning board	1	Position the hybrid inverter.
Inverter wall bracket	1	Allow the hybrid inverter to hang on the wall.
Document	1	Documentation
Communication wire	1	Connect the communication interface on the right side of the hybrid inverter and the right side of the battery module.
E0508	31	Terminals for crimping external communication wire and dry contact wire.
CE60012	8	Terminals for DC input PV wire crimping.
RNB14-5	3	Terminals for AC output grounding wire crimping.
E16-12	9	Terminals for AC phase wire crimping.
Self-tapping screw(M6*60)	4	Include flat pad and spring pad, used for fastening the wall bracket to the wall

Name	Quantity	Illustration
Power wire (+/-)	1	Connect the battery interface (+/-) on the right side of the hybrid inverter and on the right side of the battery module.
Battery rack	1 set	Fix the battery module on the floor.
Auxiliary tool	1	Adjust the distance between the battery rack and the wall, and also determine the position of the battery positioning board.
Expansion bolt (M10*100)	2	Fasten the battery rack to the ground.
200A Current transformer (Optional)	2	Use for grid side metering, calculate all house load consumption
Meter with 100A CT (Optional)	1	Use for metering the AC coupled inverter or generator current
External RSD button (Optional)	1	Rapid shut down button for outdoor installtion

Battery module

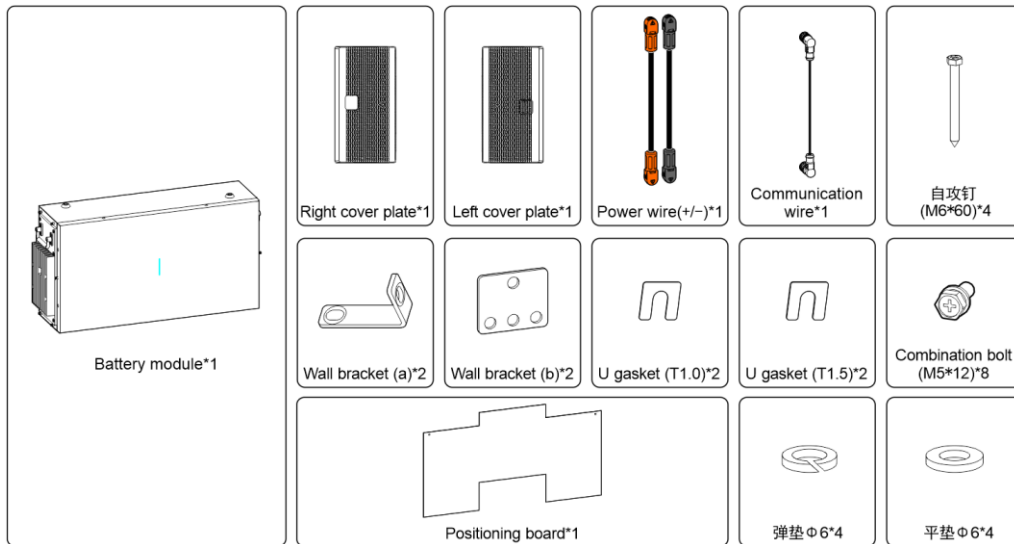

Figure3-5 Battery module packing list

Table3-2 Battery module packing list description

Name	Quantity	Illustration
Battery module	1	\
Right cover plate	1	Right cover plate of the battery
Left cover plate	1	Left cover plate of the battery
Power wire(+/-)	1	For connecting to the (+/-) port of the battery pack
Communication wire	1	For connecting the communication interface of the battery box
Self-tapping screw(M6*60)	2	For fastening the wall bracket to the wall
Flat washer ϕ 6	2	
Spring washer ϕ 6	2	
Positioning board	1	For positioning the battery box
Wall bracket(a)	2	For fixing the battery box to the wall
Wall bracket(b)	2	For fastening battery boxes to each other
U gasket(T1.0)	2	Adjust the flatness between the mounting surface and the mounting parts
U gasket(T1.5)	2	
Screw(M5*12)	8	For fastening wall bracket(b)

CAUTION

If the energy storage system ATG-ST-H01 series needs to be stored for a long time after unpacking, it is necessary to pack the device by original package and save properly.

If the battery module needs to be stored for a long time, it is necessary to take half a year to charge.

3.4 Battery Module Configuration

The ATG-ST-H01 series products can be flexibly configured with up to four battery modules.



Figure3-6 Configuration diagram

3.5 System Diagram

For system wiring diagrams of various application scenarios for ATG-ST-H01 series products, please refer to Appendix B for details.

3.6 Mechanical Installation

The installation carrier for ATG-ST-H01 product should be with a certain structural strength, such as cast-in-place reinforced concrete walls or brick structure walls, etc. For other special walls, corresponding strengthening measures should be taken according to the actual situation.

WARNING

The battery module is very heavy, please be careful when handling them!

There is a risk of injury if the battery module is not handled properly during transporting.

CAUTION

1. Keep the installed place far away from the conduit of water, electricity or gas.
 2. Do not open the inverter side cover and front cover before drilling to avoid dust and metal shavings from entering during drilling.
 3. After drilling, please clean the scrap in the holes.
-

- Step 1 Assemble the auxiliary tool onto the base module, and then push the assembled base against the wall to determine the installation place, as shown in Figure3-7, Figure3-8.

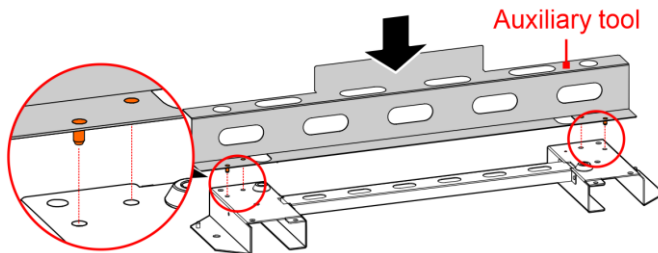

Figure3-7 Assemble the auxiliary tool

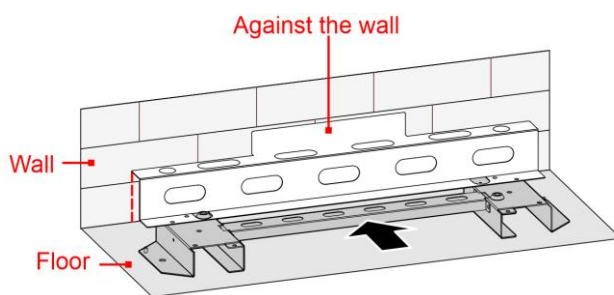

Figure3-8 Push the assembled base against the wall

CAUTION

Ensure that the installed floor and wall are flat and horizontal (flatness within 4mm) and the installed floor horizontal angle is 0° . If not, please use gasket to make the floor and wall horizontal. The U gasket is used as follows.

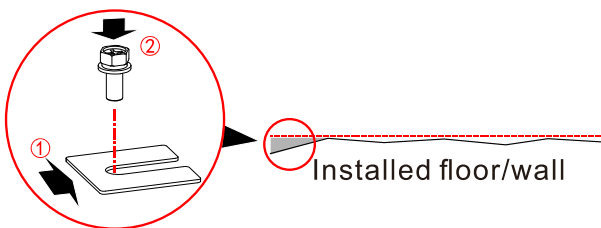

Figure3-9 U gasket installation

NOTE

The installation procedure for battery module is the same, in this section, we take 2 battery modules as an example to illustrate.

- Step 2 Tear off the back glue of positioning boards and mark the mounting holes of base module, battery modules and hybrid inverter, as shown in Figure3-10, Figure3-11.

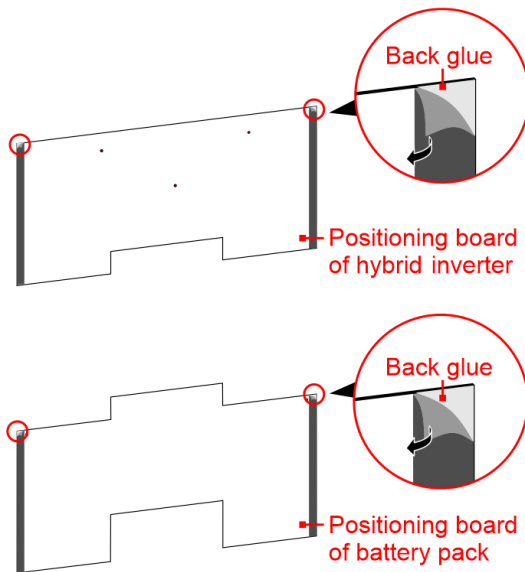

Figure3-10 Tear off the back glue

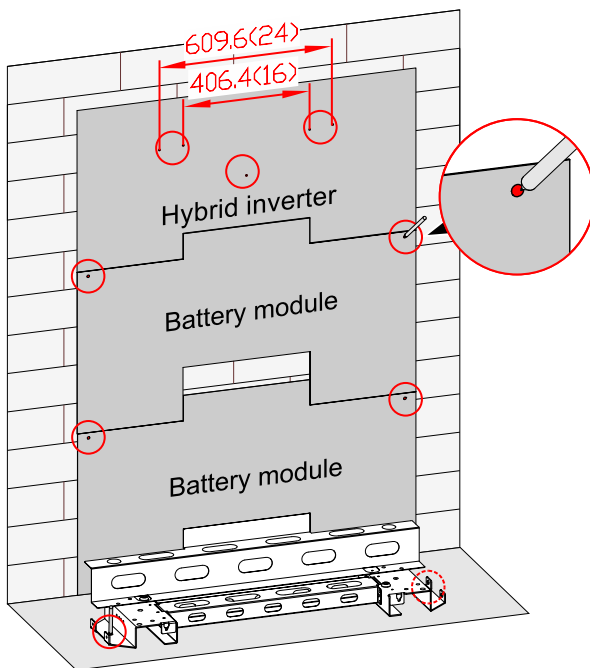

Figure3-11 Mark mounting holes

 **NOTE**

The wall bracket positioning holes are installed at 16 or 24 inches (to be determined by the load-bearing columns of the house), if the spacing of the holes on the positioning board does not match the load-bearing spacing, please refer to the wall bracket holes for positioning.

Step 3 Remove the positioning boards and auxiliary tool.

Step 4 Drill base holes and install expansion bolts according to the mark position.

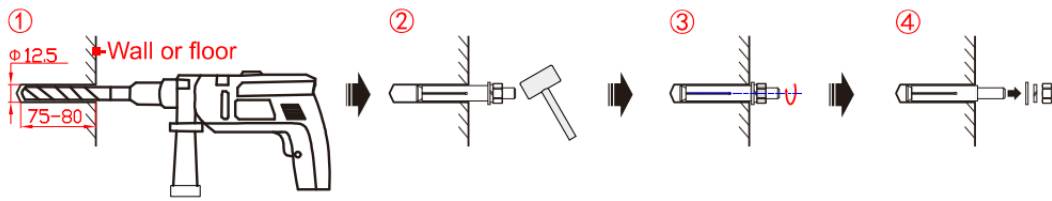

Figure3-12 Drill holes and install expansion bolts

CAUTION

During drilling, please wear safety goggles and a dust mask to prevent dust from entering your eyes. After drilling, please clean the scrap in the installation holes, and then perform the installation.

NOTE

If the battery module and inverter need to be mounted on the concrete wall, you need to prepare the expansion bolts by yourself, the recommended specifications and installation methods are as follows.

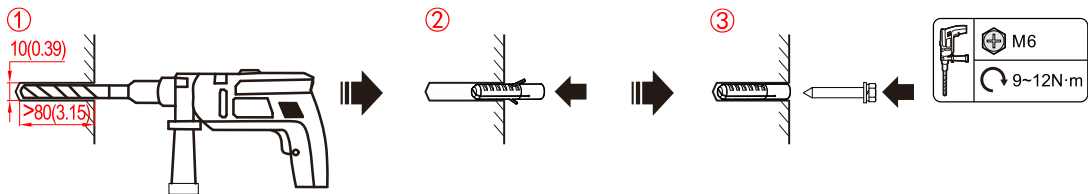

Figure3-13 Drill holes and install expansion bolts

Step 5 Fasten the base module, as shown in Figure3-14.

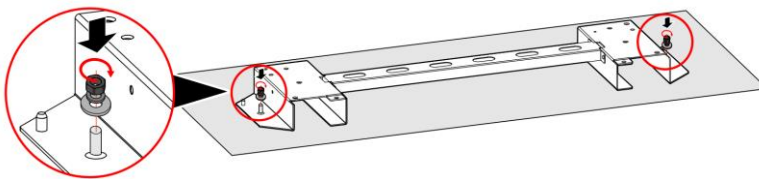

Figure3-14 Install the expansion bolt (unit: mm (in))

Step 6 Lead the cover plate into the base module and fix it by screws, as shown in Figure3-15.

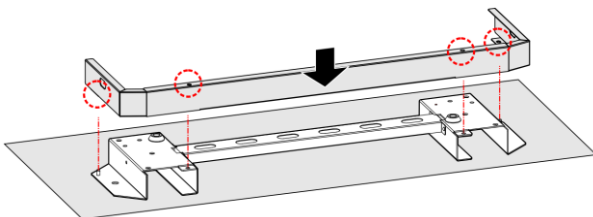

Figure3-15 Install cover plate of base module

Step 7 Install battery modules.

1. Fix the bottom battery module with base module by wall bracket (b), as shown in Figure3-17.

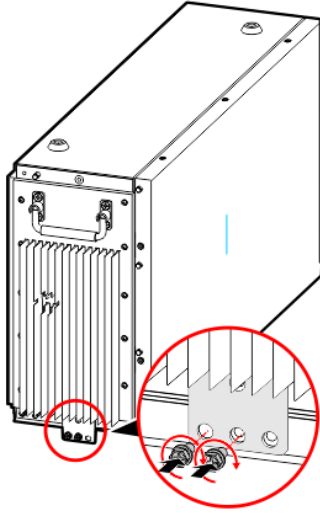

Figure3-16 Wall bracket (b) installation

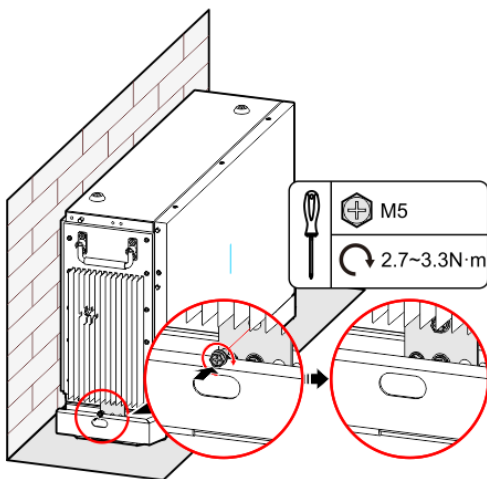

Figure3-17 Fix the bottom battery module with base

2. Fix the wall bracket (a) of bottom battery module, as shown in Figure3-18.

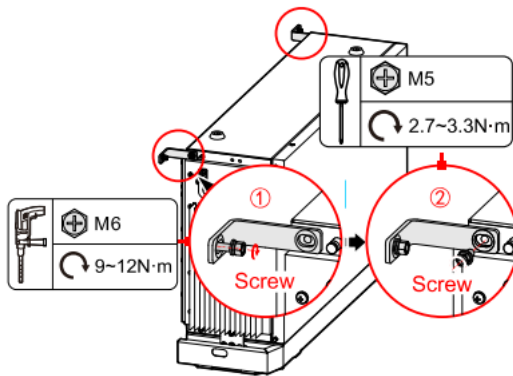

Figure3-18 Fix the wall bracket (a)

Step 8 Place the battery module onto the lower battery module, as shown in Figure3-19.

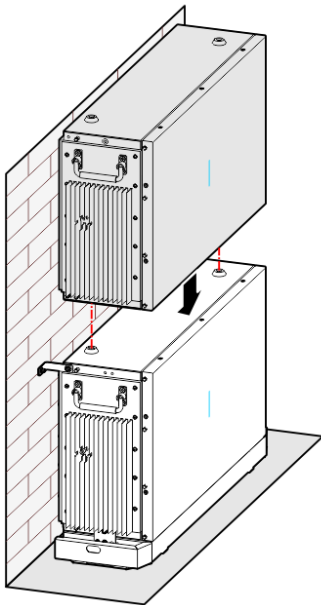

Figure3-19 Place the battery module

⚠ CAUTION

While placing the battery module, the bottom limit holes of the upper battery module should match the screw on the top of the below battery module.

2. Fix the battery module, as shown in Figure3-20.

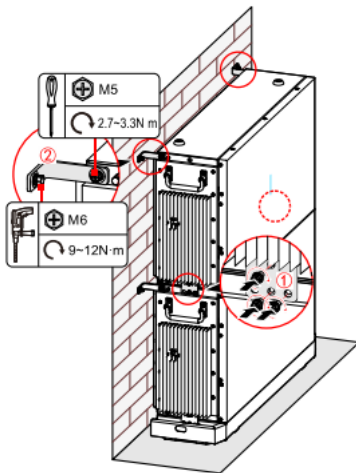

Figure3-20 Fix the battery module

Step 9 Install the hybrid inverter.

1. Fix the wall-mounted bracket, as shown in Figure3-21.

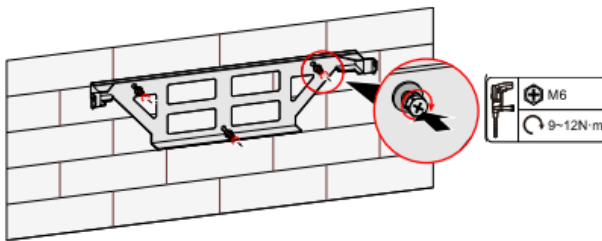

Figure3-21 Fix the wall-mounted bracket

2. Hang the hybrid inverter to wall-mounted bracket, as shown in Figure3-22.

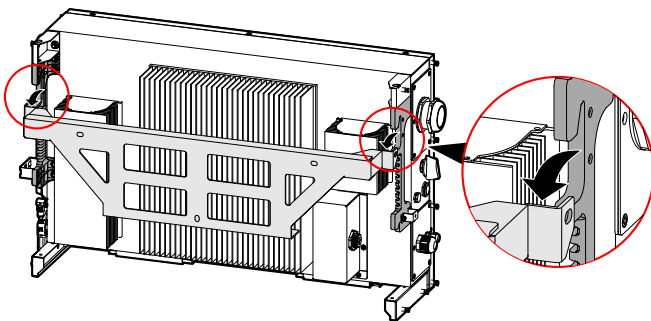

Figure3-22 Hang the hybrid inverter to wall-mounted bracket

3. Fix the hybrid inverter, as shown in Figure3-23.

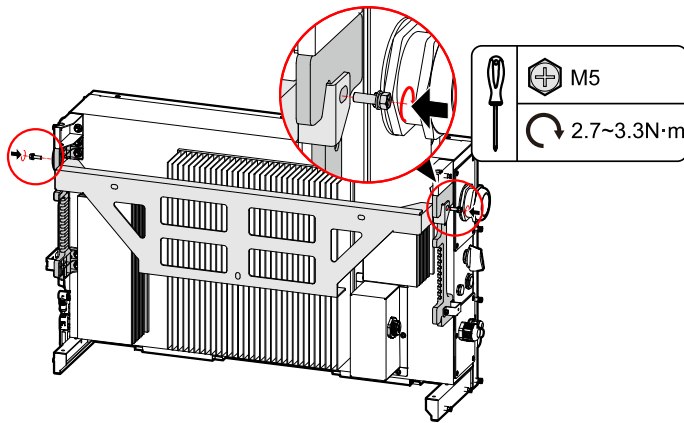

Figure3-23 Fix the hybrid inverter

Step 10 Fasten the support.

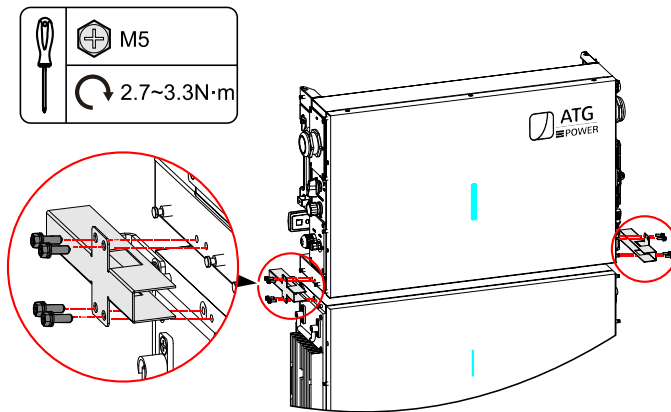

Figure3-24 Fasten the support

NOTE

This support must be installed in order for the batteries to have the same ground as the inverter.

----End

3.7 Electrical Connection

CAUTION

When wiring, the wire and conduit should be passed through the side cover plate first. As shown in below.

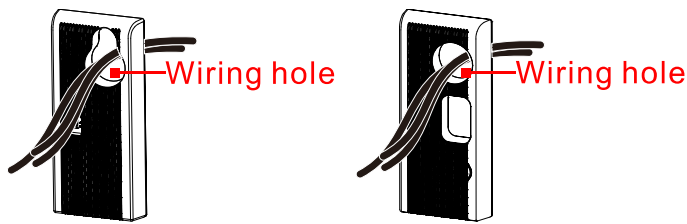

Figure3-25 Wiring precaution

3.7.2 Connecting Materials Preparing

Step 1 Conduit and wire requirement is as shown in below.

Table3-3 Wire Requirement

No.	Wire	Wire color recommend	Wire gauge	Terminal
1	PV power cable (+,-)	-	12AWG	E4012
2 ^{※1}	Signal cable	-	24AWG	E0508
3	AC power cable (L1,L2,N)	Black, Red, White	6AWG	E16-12
4	PE cable	Green/Yellow	8AWG	RNBS8-5
5 ^{※2}	Signal cable		24AWG	E0508

NOTE

※1 For Meter, Current transformer, Distribution box, Generator, external RSD button signal, etc.

※2 For external RSD button signal, optional

Step 2 Dismantle the PV cover plate, AC&COM1 cover plate and BATT. &COM cover plate(only for installing external RSD button) drill the hole.

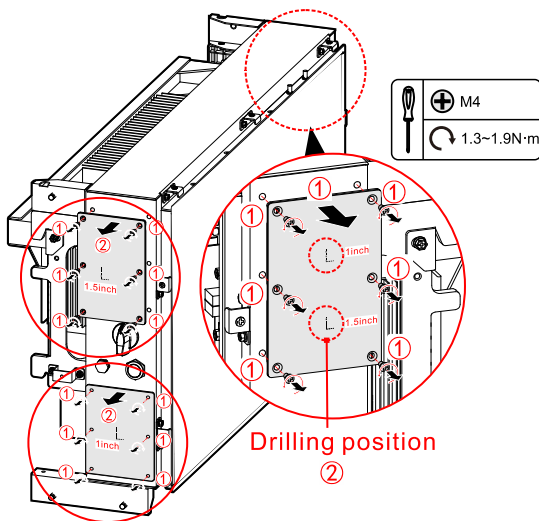

Figure3-26 Dismantle the cover plate and drill the hole

Table3-4 Conduit Requirement

No.	Cover plate	Conduit Size recommend	Hole Size
1	PV cover plate	33 mm (1.2992 inch)	1 inch
2	AC&COM1 cover plate(COM1)	33 mm (1.2992 inch)	1 inch
3	AC&COM1 cover plate(AC)	48 mm(1.8898 inch)	1.5 inch
4	BATT.&COM cover plate(COM)	-	-

Step 3 Dismantle the front panel, and then disconnect light panel wire. as shown in below.

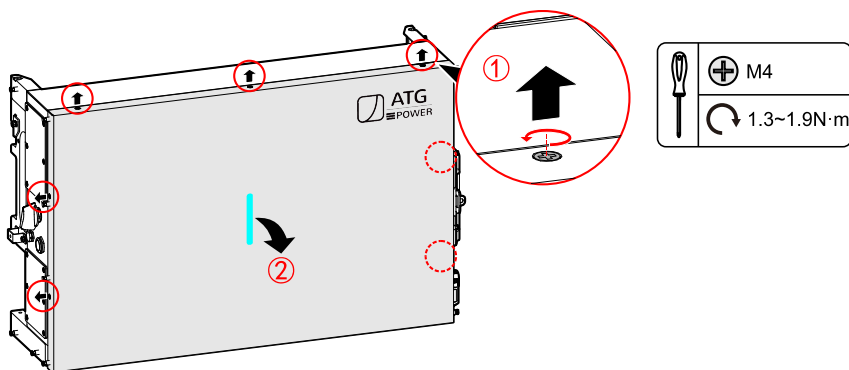

Figure3-27 Dismantle the front panel

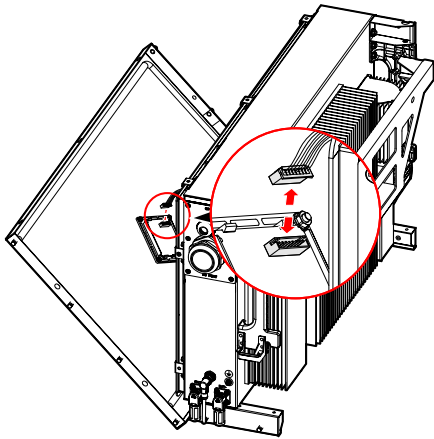

Figure3-28 Disconnect the light panel wire

3.7.3 DC Input (PV) wires and Grounding wire Connection

CAUTION

- Ensure that the connection between PV array and the hybrid inverter at positive pole and negative pole is correctly.
- The DC input voltage should be less than the max. input voltage of the hybrid inverter.
- It's forbidden to connect the grounding wire with positive pole or negative pole of PV array, or it will lead to hybrid inverter damage.

Step 1 Ensure that the DC switch on the hybrid inverter turns to OFF.

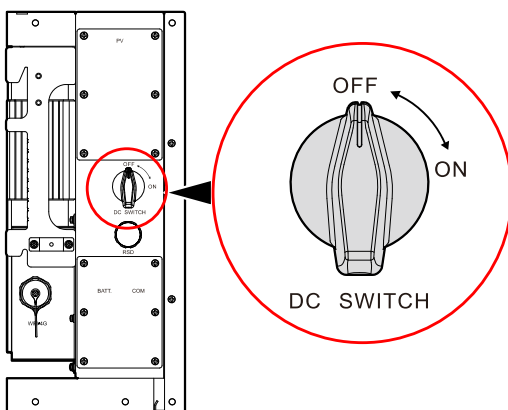

Figure3-29 DC switch status

NOTE

Do not operate when locked.

Step 2 Strip the insulation layer of positive wire and negative wire for about 9mm, as shown in Figure3-30.

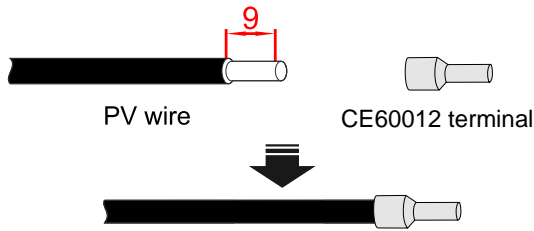
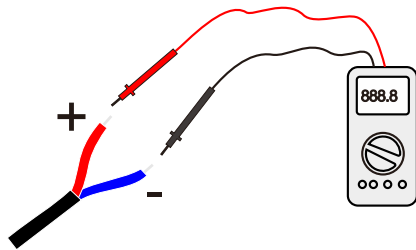

Figure3-30 Stripping diagram of DC input (unit: mm (in))

NOTE

It is better to use different color for the positive and negative of PV input. It is recommended to use red wire as the positive wire, use black wire as negative wire to avoid wrong connection. If using the wires of other color, please confirm the corresponding connection relationship.

Step 3 Measure the voltage and check if the positive and negative is connected properly and if the voltage within the input range of the hybrid inverter.



Measure the voltage of PV string <math>< 500V</math>

Figure3-31 Measure the voltage

Step 4 Strip the insulation layer of wire for about 10mm, as shown in Figure3-38.

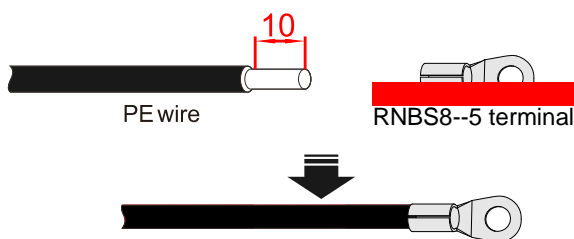

Figure3-32 Stripping diagram of PE (unit: mm (in))

Step 5 Lead the PV wires and grounding wire go through the conduit the PV cover plate and connect them to corresponding terminals, then fix the PV cover plate.

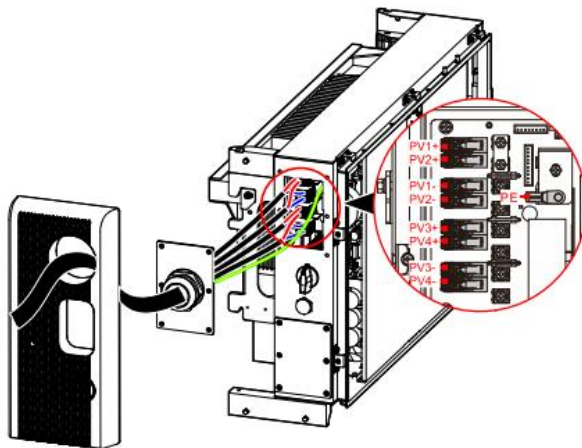

Figure3-33 PV input and PV part grounding wiring



After wiring, it needs to be waterproofly sealed.

Step 6 Fix the AC cover plate.

3.7.4 External RSD button connection

If the ATG-ST-H01 series product needs to be installed indoors, the external RSD button needs to be installed outdoors and connected to the Hybrid inverter for the system's fast shutdown function.

 **NOTE**

The ATG-ST-H01 series is compatibility with Tigo TS4-A-F/2F for rapid shutdown function.

Step 1 Prepare a 1NC+1NO External RSD button.

Step 2 Strip the insulation layer of wire for about 8mm, as shown in Figure3-40.

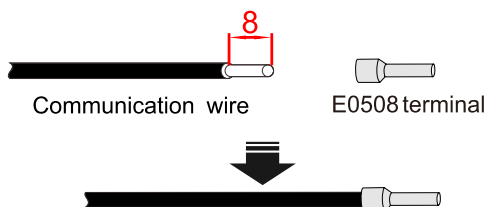

Figure3-34 Stripping diagram of communication wire (unit: mm (in))

Step 3 Unscrew the build-in button terminal after loosening the build-in button terminal.

Step 4 Use the equipped external terminal for wiring (please see Figure3-36 for detailed wiring diagram). After wiring, plug the equipped external terminal to the internal terminal and tighten it

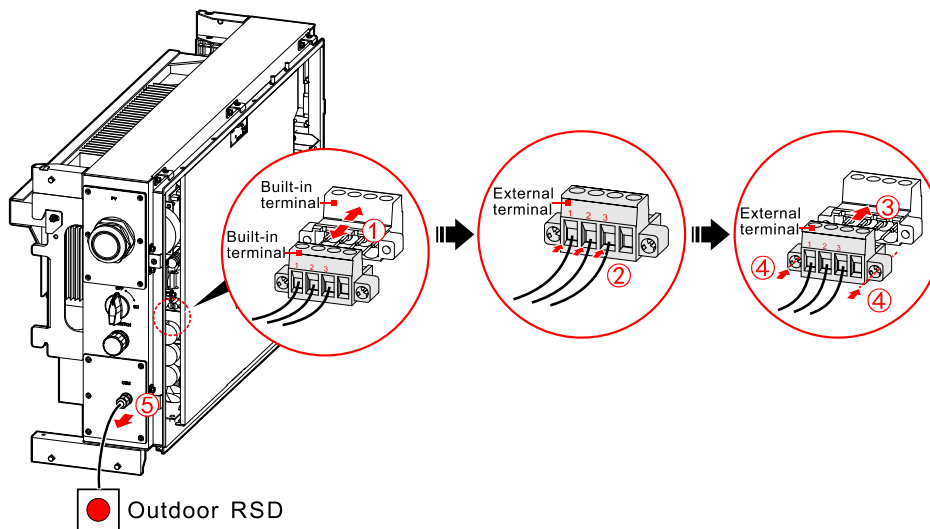

Figure3-35 External RSD button connection

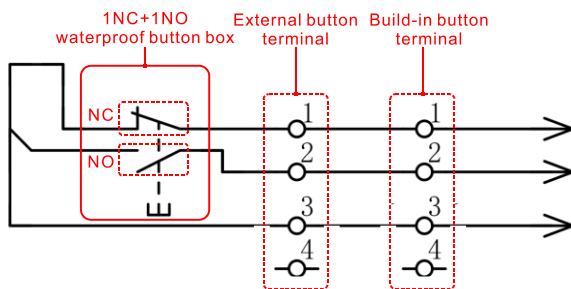

Figure3-36 External terminal wiring diagram

Step 5 Fix the AC cover plate.

3.7.5 AC wires, Grounding wire and Signal wires Connection

CAUTION

DO NOT shares one AC for switch several hybrid inverters.

DO NOT connect with load between hybrid inverter and AC switch.

During wiring, please pay attention to distinguish the AC live wire, neutral wire and grounding wire.

To ensure the hybrid inverter can be disconnected with load safely, we suggest equipping independent dipolar breaker for each hybrid inverter to protect the hybrid inverter.

Table3-5 Recommended AC breaker specification

Hybrid inverter Model	AC input and output (GRID) specification	AC input (LOAD) specification
ATG-ST-H01-7600	40A	40A
ATG-ST-H01-9600	50A	50A
ATG-ST-H01-10000	60A	60A
ATG-ST-H01-11400	60A	60A
ATG-ST-H01-12000	63A or above	63A or above

Step 1 Ensure that the external breaker are all OFF.

Step 2 Strip the insulation layer of wire for about 12mm, as shown in Figure3-37.

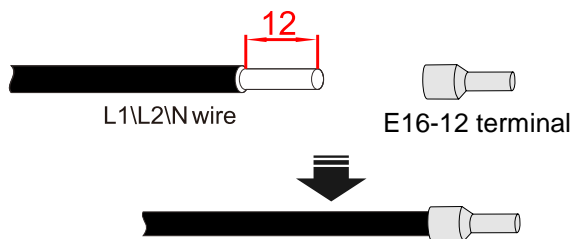

Figure3-37 Stripping diagram of L1\L2\N (unit: mm (in))

Step 3 Strip the insulation layer of wire for about 10mm, as shown in Figure3-38.

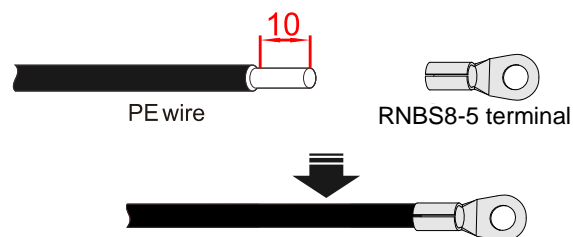

Figure3-38 Stripping diagram of PE (unit: mm (in))

Step 4 Lead the grid, load and generator wires go through the AC&COM1 cover plate and connect them to corresponding terminals, and then screw all terminals by screwdriver one by one.

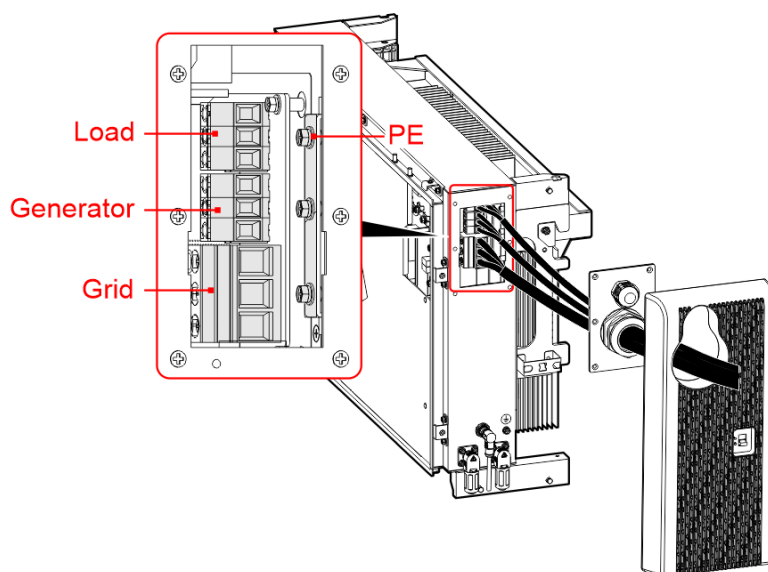

Figure3-39 AC connection

Step 5 Strip the insulation layer of wire for about 8mm, as shown in Figure3-40.

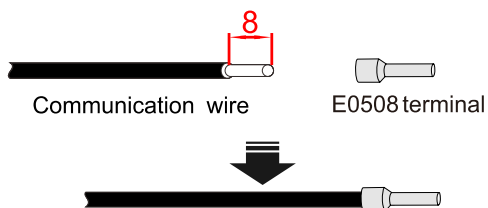

Figure3-40 Stripping diagram of communication wire (unit: mm (in))

Step 6 According to actual use, lead the communication wires go through the wiring hole and connect them to corresponding devices or distribution box(BTS200-US).

If the home system is a partial house load backup system, as shown in Appendix C in System Wiring Diagrams 1,3,5, it needs to be connected How many terminals such as Table

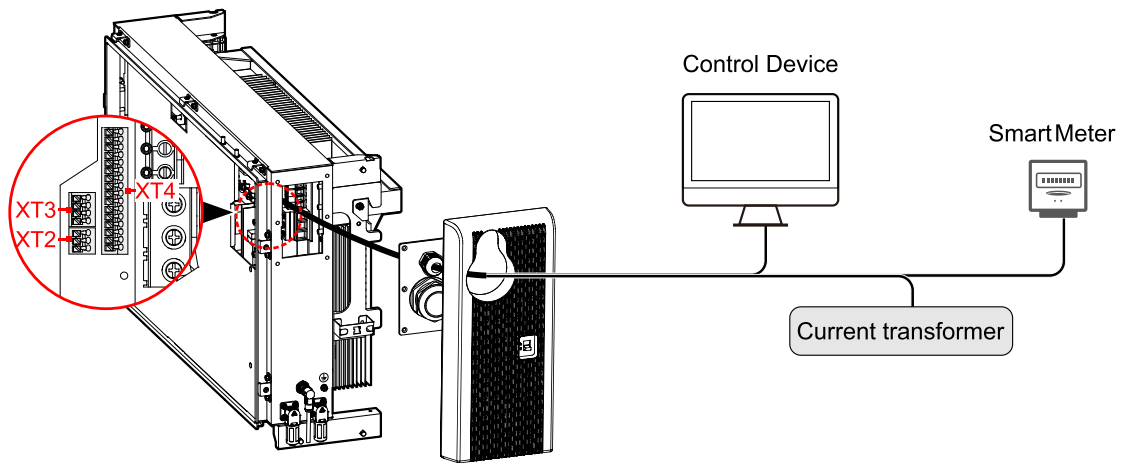

Figure3-41 Communication connection

Table3-6 Port definition

Position	No.	Port definition	Description
XT3	1	Current transformer 1+	Connect to 200A CT
	2	Current transformer 1-	
	3	Current transformer 2+	
	4	Current transformer 2-	
XT4	1	RS485_B-Sunspec	Connect to control device
	2	RS485_A-Sunspec	
	5	RS485_B-Meter	Connect to METER
	6	RS485_A-Meter	
	9	Output_I/O-_GEN	Connect to generator
	10	Output_I/O+_GEN	

NOTE

If the system is whole house load backup system, please refer to system wiring diagram 2,4,6 in Appendix B. For details, see the distribution box BTS200-US user manual

CAUTION

During wiring, the communication wire and power wires should be separated.

The wires of RS485_A and RS485_B should be twisted together respectively.

After wiring, it needs to be waterproofly sealed and the side of the connecting pipe should be waterproof

Step 7 Fix the AC cover plate.

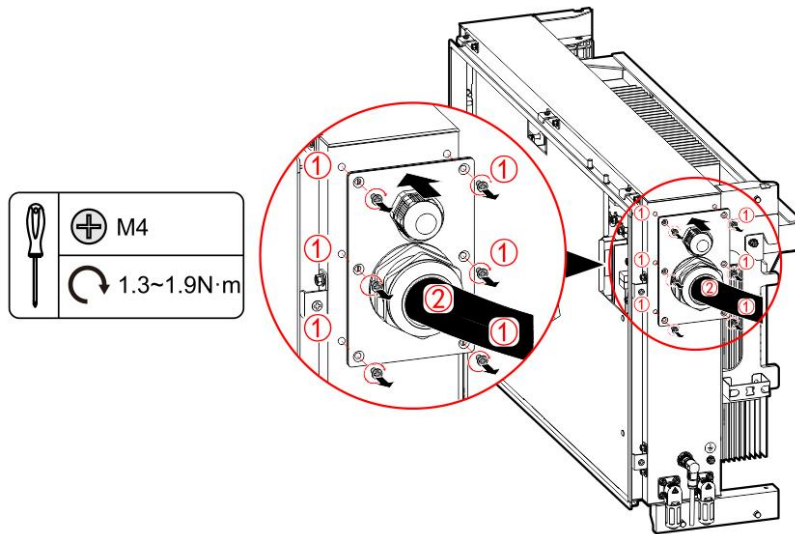

Figure3-42 Fix the AC cover.

3.7.6 Meter connection and setting (Optional)

With reference to system diagram, the meter (Chint DTSU666) is used for calculating solar inverter or generator power. Please connect as show in Figure 3-60 and do the following setting as show in Figure 3-60.

Position	No.	Port definition	Description
XT4	5	RS485_B	Connect to METER B port
	6	RS485_A	Connect to METER A port

Position	No.	Port definition	Description
METER	1	I1*	Connect to 100A CT I1* (Gen cable L1)

Position	No.	Port definition	Description
	3	I1	Connect to 100A CT I1 (Gen cable L1)
	4	I2*	Connect to 100A CT I2* (Gen cable L2)
	6	I2*	Connect to 100A CT I2 (Gen cable L2)
	2	L1	Connect to ATG-ST-H01 AC-GEN port L1
	5	L2	Connect to ATG-ST-H01 AC-GEN port L2
	10	N	Connect to ATG-ST-H01 AC-GEN port N

CAUTION

Note the direction of cables pass through CT.

After wiring, the meter needs to be waterproofly sealed

If the meter used in the grid side of ATG-ST-H01 product, the address should be set to A-001 . As shown in Figure3-43.

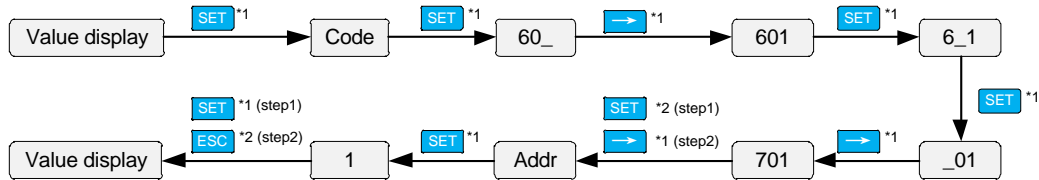

Figure3-43 The setting of the smart meter address (split- phase)

3.7.7 CT connection (Optional)

With reference to system diagram, CT is used for calculating whole house load consumption. Please connect as show in Figure 3-60

Position	No.	Port definition	Description
XT3	1	Current transformer 1+	Connect to 200A CT S1 (Grid cable L1)
	2	Current transformer 1-	Connect to 200A CT S2 (Grid cable L1)
	3	Current transformer 2+	Connect to 200A CT S1 (Grid cable L2)
	4	Current transformer 2-	Connect to 200A CT S2 (Grid cable L2)

! CAUTION

Note the direction of cables pass through CT.

Please notice positive and negative CT cable and the direction of cables.

3.7.8 Generator signal connection (Optional)

If a generator is installed in the home system, it is necessary to connect the remote control signal line to the generator to achieve remote control. The generator must have 2 wire control port

Position	No.	Port definition	Description
XT4	9	Output_I/O-_GEN	Generator 2 wire control port COM
	10	Output_I/O+_GEN	Generator 2 wire control port Power

3.7.9 WIFI Communication Connection

The hybrid inverter is equipped with WIFI, install it to the WIFI/4G port (as shown in Figure3-44) to monitor on the internet. The monitor way is as shown in Figure3-45.

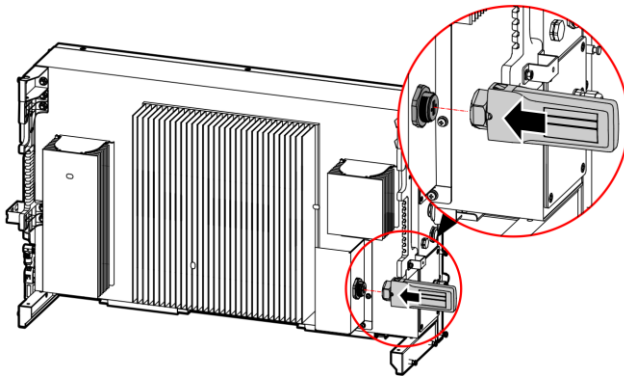

Figure3-44 WIFI communication connection

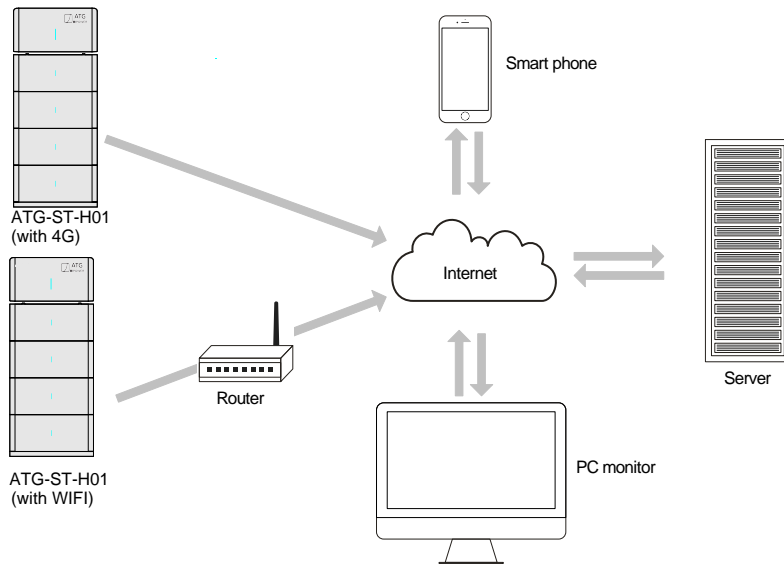

Figure3-45 Communication way

Step 2 Check all wire connection is right.

Step 3 Plug the wire to the light panel and then reinstall the front panel to the hybrid inverter.

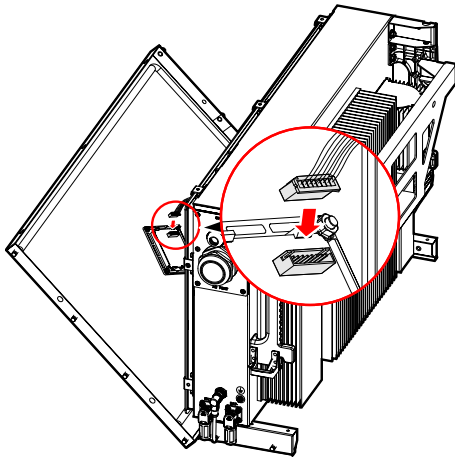

Figure3-46 Plug the wire to the light panel

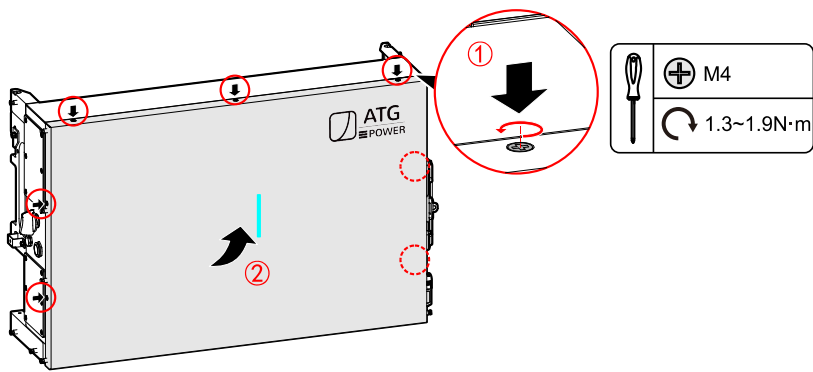

Figure3-47 Reinstall the front panel

⚠ CAUTION

After finish installing the cover, please check the waterproof of cover, ensure that the waterproof level reach the requirement of NEMA3R.

3.7.10 Battery Module Connection

Connect battery module to battery module and hybrid inverter.

⚠ CAUTION

While connecting the inner wires of system, it is necessary to make the handle on the battery module vertical to the side, and lead the battery +/- and BMS communication wires go through the handle, and then connect them.

The inner wiring of system must use the configured battery module wires.

During wiring, ensure that the connection of battery module + and battery module - are all right.

📖 NOTE

In following figure, we take 1 hybrid inverter and 4 battery modules as an example to illustrate. The wiring of other configuration is the same.

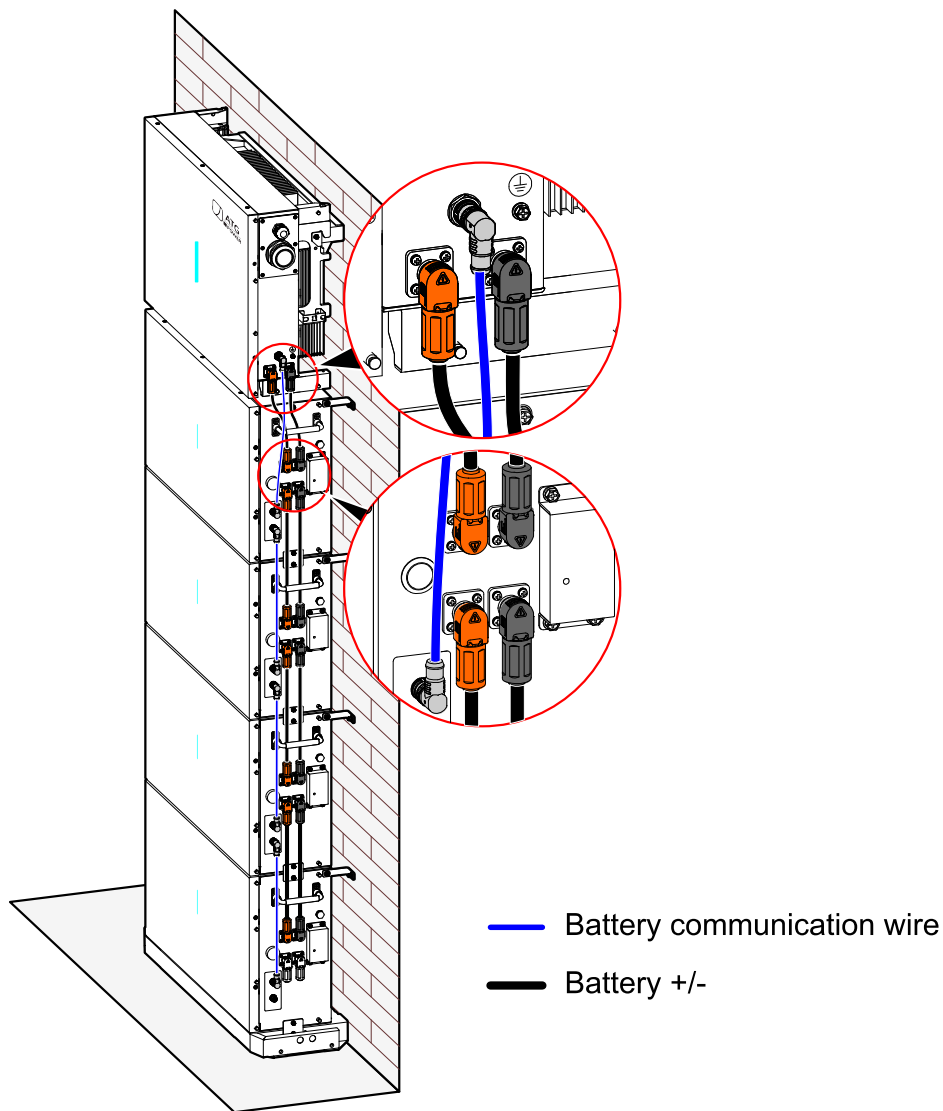

Figure3-48 Communication interface connection

----End

3.8 Install Side Cover Panel

CAUTION

While fixing the cover panels, it is necessary to lead the corresponding wires go through the groove of cover panel and fasten them to avoid extruding for the wires and even cause damage for the wires and affect the normal use.

Step 1 Fix the bracket (left) and bracket (right) with M4, as shown in Figure3-49.

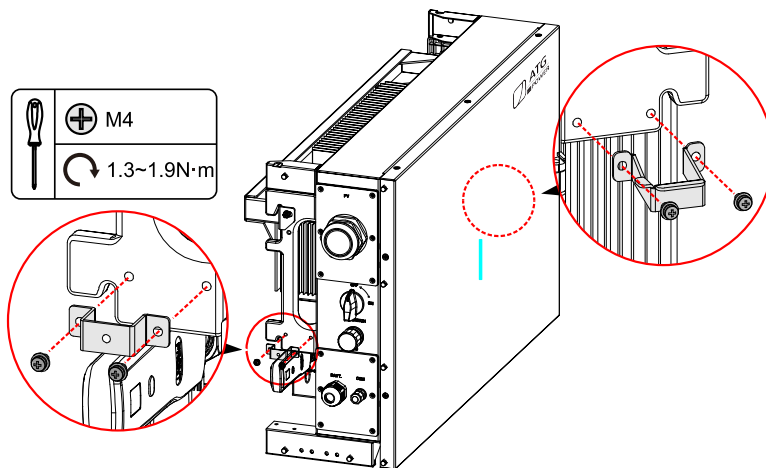

Figure3-49 Fix the bracket

Step 2 Fix the side cover panels, as shown in Figure3-50.

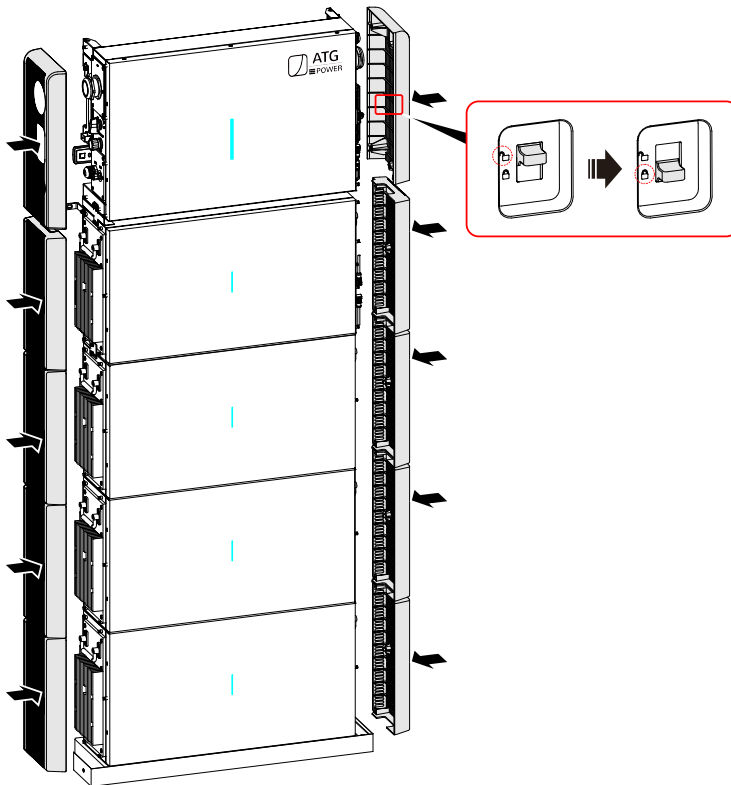

Figure3-50 Fix the side cover panel

----End

3.9 Check the Installation

After installation, check the following items:

- Check if the ATG-ST-H01 product is installed firmly.
- Check if all the wiring is tightened.

4 APP Operation

4.1 First Startup

Step 1 Login the following website to download the APP and do WIFI configuration.

- Download APP

APPSTORE: <https://apps.apple.com/cn/app/wisesolar-plus/id1510470362>



GOOGLE PLAY: <https://play.google.com/store/apps/details?id=com.ATG.Wisesolarpro>



Step 2 Register, as follows.

1. Open the APP.
2. Tap **Register** button.
3. Select **By mobile phone** or **By Email** according to actual condition.
4. Enter corresponding information according to prompting.

 **NOTE**

Logger code can be entered by scanning the QR code of WIFI on the device.

For detail operation, please see the quick start guide of APP.

Operation guide: <https://energy.ATG.com/quickStart>



Step 3 After registering, login according to the registered **mobile phone/Email** and **password**, as shown in Figure4-1.

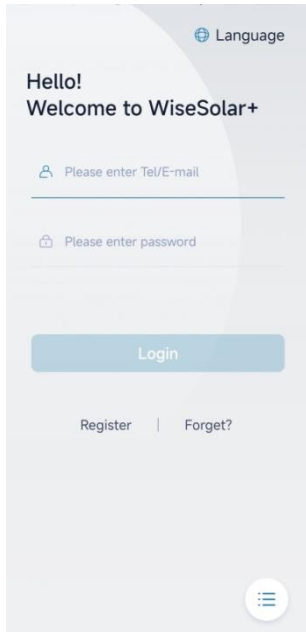

Figure4-1 Login page

Step 4 After entering the main page, it will show the prompting "No plant. Go and create a new one" to build a new plant, as shown in Figure4-2.

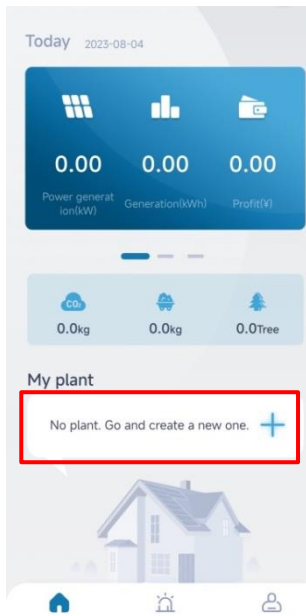

Figure4-2 Main page

- Step 5 After entering corresponding information, tap **Next** button at the bottom of the page, it will turn to scan QR code page. Tap the left scan icon to scan the S/N code on the WIFI module (also, you can enter the S/N code manually). And then tap **Save** button, as shown in Figure4-3, Figure4-4.

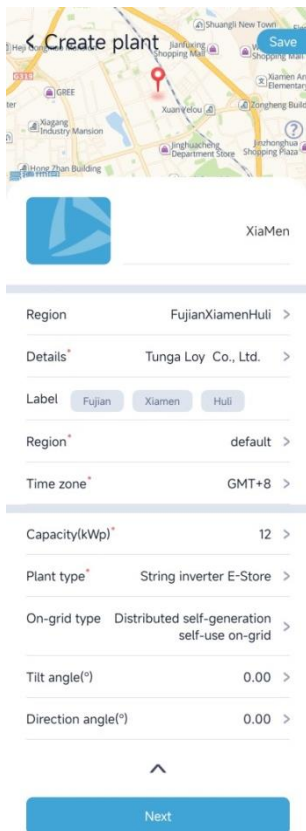

Figure4-3 Enter corresponding information

 **NOTE**

The item with "*" is required.

On-grid type is used to select the connection is off-grid or pure energy storage or pure inverter to grid, this item is not necessary. We suggest to select **Distributed self-generation self-use on-grid**.

Plant Type is used to select the device type, for ATG-ST-H01 , it must select **String inverter E-store**, as shown in Figure4-3. If the wrong choice is made, it will affect the main energy flow in main page.

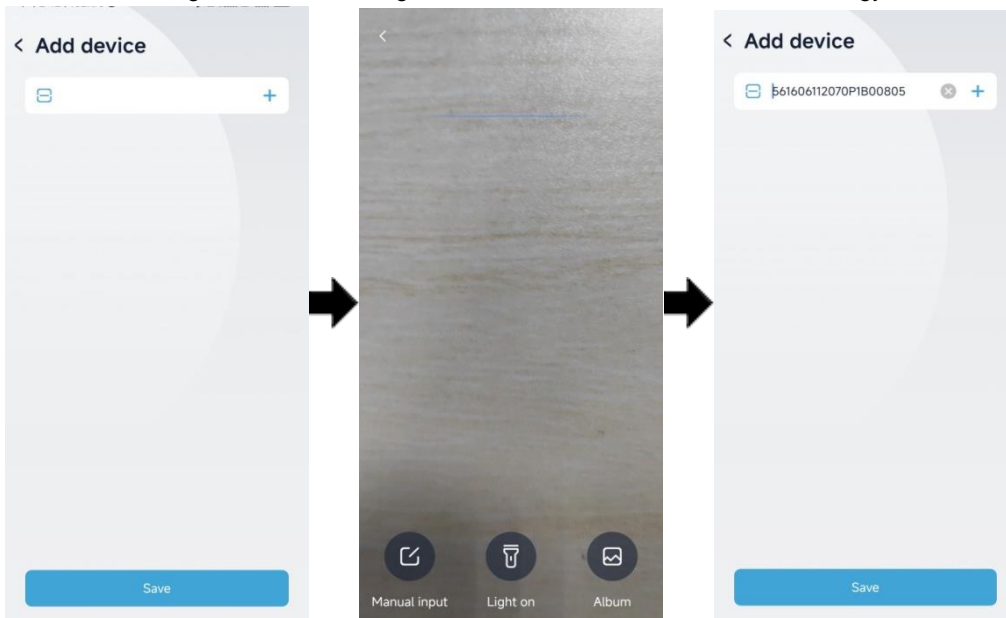

Figure4-4 Add device

Step 6 Back to main page and tap the built power plant, as shown in Figure4-5.

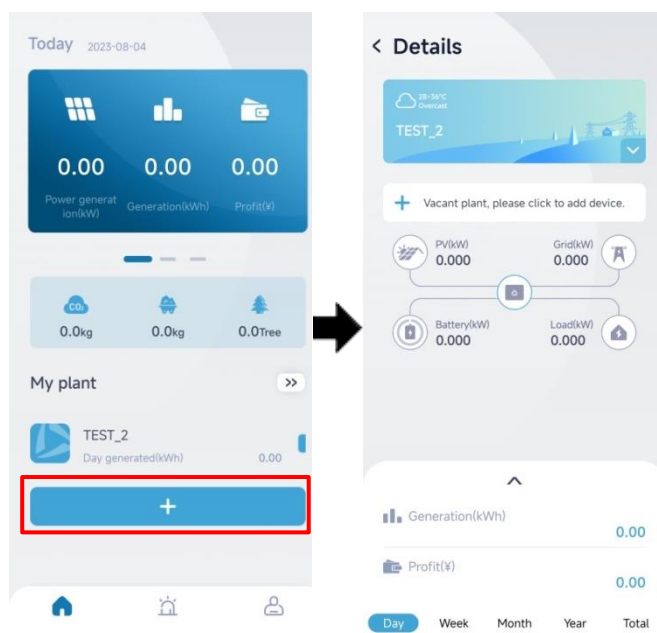

Figure4-5 Plant details interface

Step 7 Select **user icon** at the left bottom corner of the page and enter **edit price** to configure the electricity price, so as to calculate the electricity price in the future, as shown in Figure4-6.

Step 8 We can choose the **Basic price**, **TOU price** or **Step price** for the profit calculation.

 **NOTE**

You can set the currency type under ID.

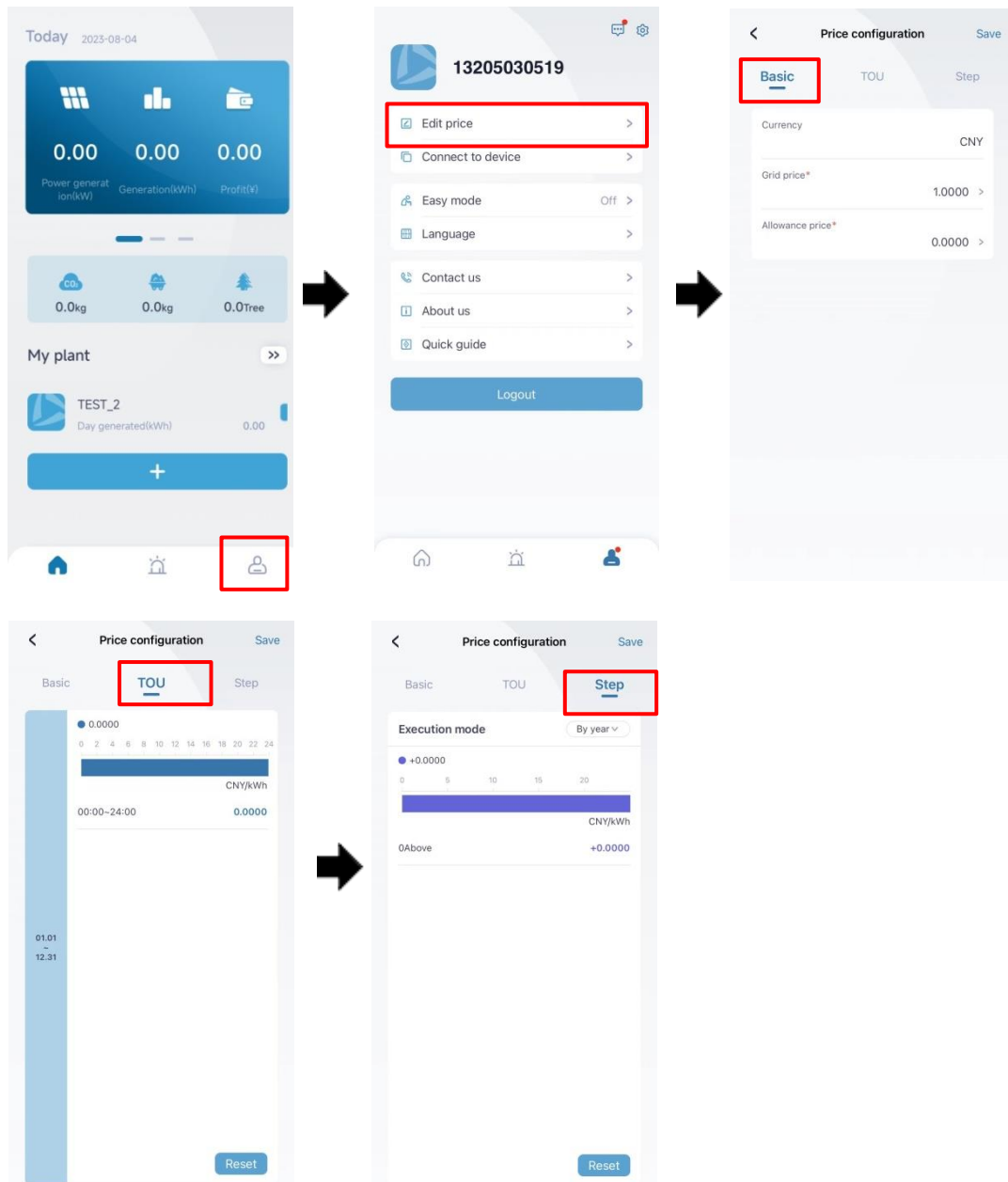

Figure4-6 Plant details interface

Step 9 Select + **Vacant plant, please tap to add device** to scan the QR code of the collector, the device will be added to the built plant, as shown in Figure4-7.

NOTE

When the surrounding is dark, please tap the **Light On** button at the bottom to start the flashlight to enhance the brightness.

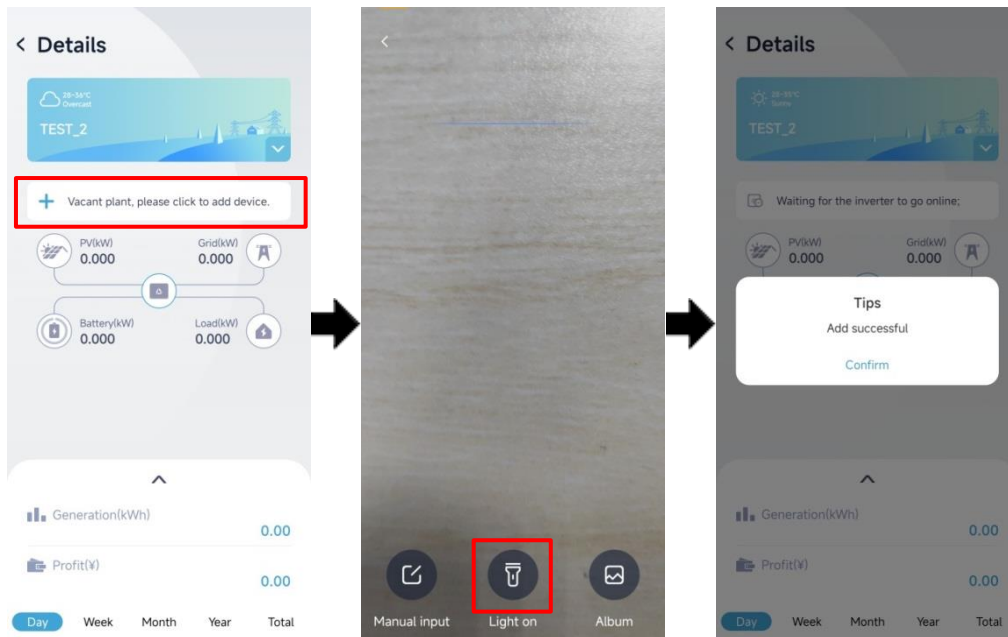

Figure4-7 Add new device

NOTE

When the WIFI collector is added for the first time, it is necessary to tap **ConFigure network** button to configure, if the WIFI collector has been added, the configuration needn't to be done.

Step 10 Tap the right bottom icon in the main page, then tap **Connect to device**, and then tap **WiFi** icon, it will show the tips. Tap **Confirm** button, it will turn to WiFi list. Select the WiFi whose name is the same as that of WIFI module, and then enter the default password: admin12345678, the WIFI module will be connected, as shown in Figure4-8.

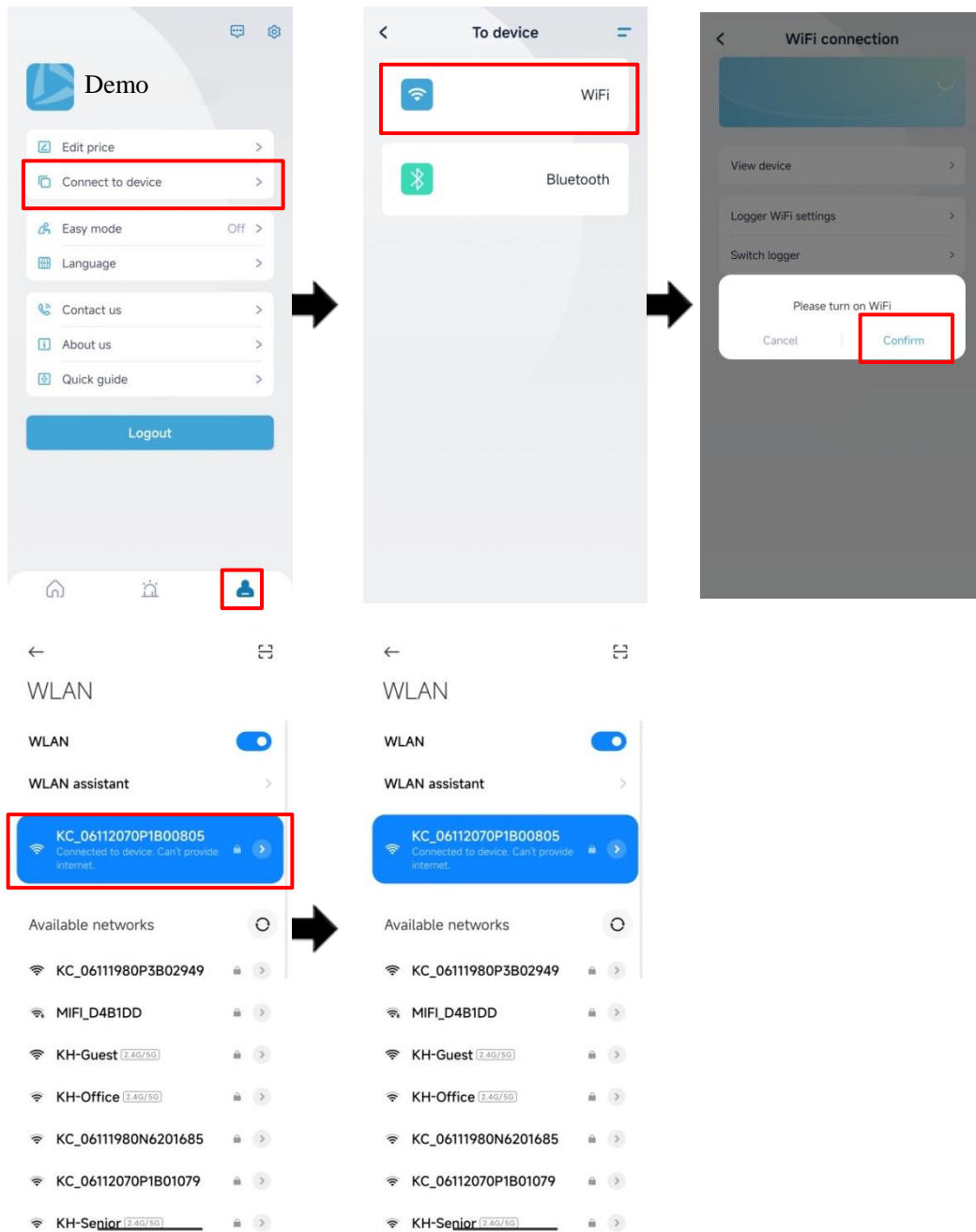

Figure4-8 Connect device

Step 11 Tap the device S/N (last page as shown in Figure4-8) to enter the page as shown in Figure4-9. Tap **Logger WiFi Settings**, select an available WiFi in **Hotspot list**, when it prompts: **WiFi connecting successful**, tap OK. At this time, the currently connected WiFi should show **Connected**.

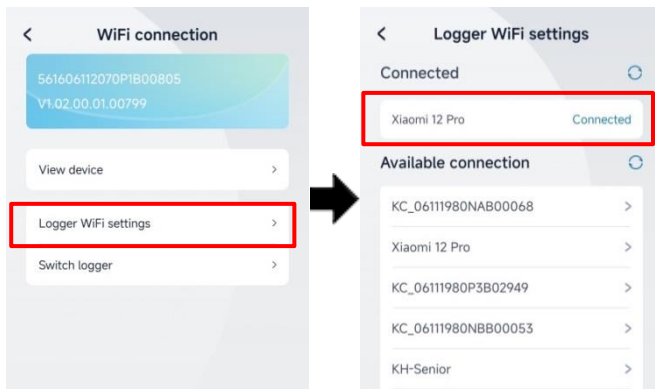

Figure4-9 Configure WiFi

Step 12 Back to main page, the device status turns to online from offline, as shown in Figure4-10.

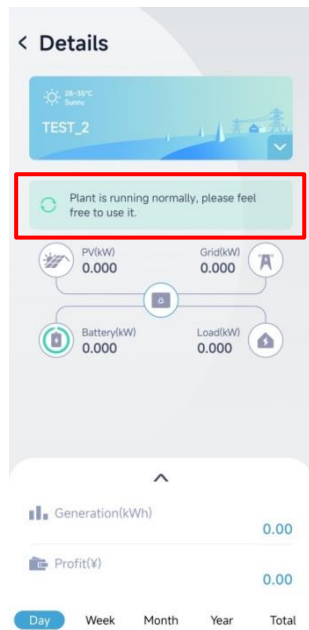

Figure4-10 Device list



When the logger is offline for a long time, it may cause loss of energy data.

----End

4.2 Information Query

Step 1 In main page, tap **My plant** - device list to enter the device list page, as shown in Figure4-11.

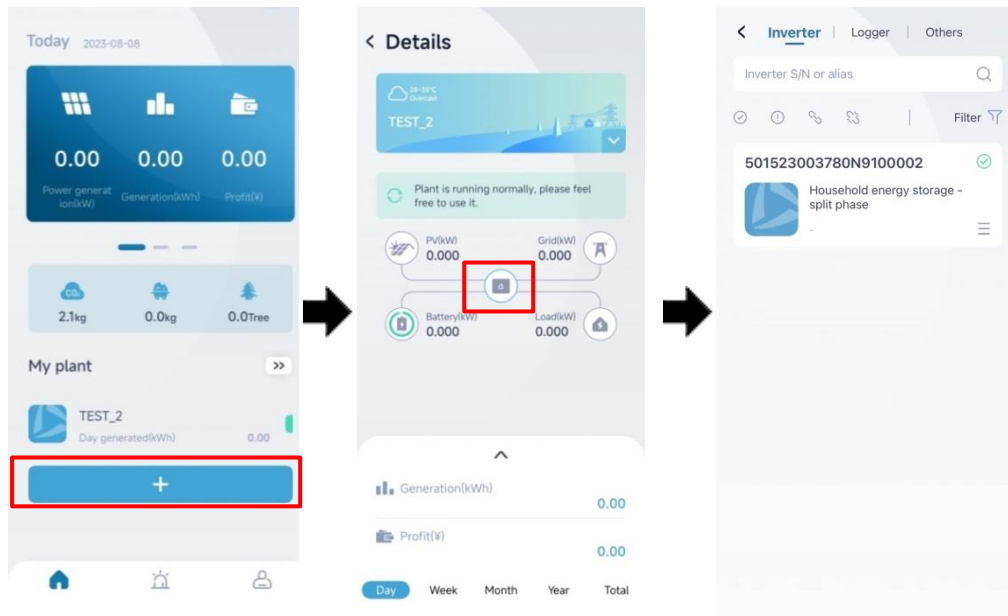

Figure4-11 Device list

Step 2 Tap the corresponding S/N of device to view the inverter info, as shown in Figure4-12.

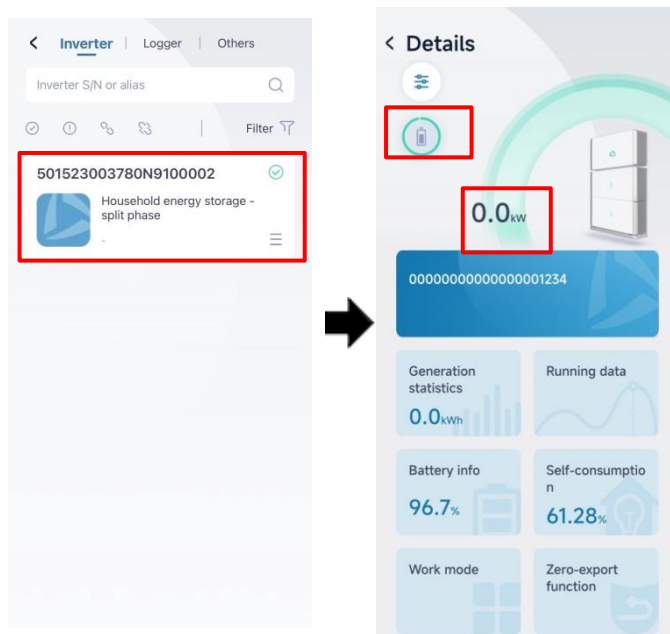

Figure4-12 Device detail

Step 4 Tap the items below to view more info, such as generation statistics, running data, battery info, self-consumption, work mode, zero-export function and battery protection setting.

----End

4.3 Running Data

4.3.1 Running Data

Grid info

Tap **Running data** in Figure4-13, you can check the voltage and current, grid power and frequency of L1/L2.

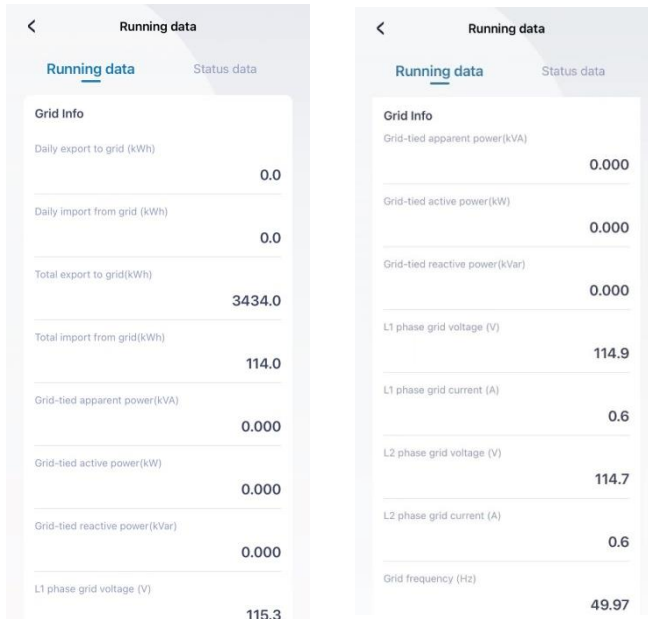

Figure4-13 Grid info page

Battery info

In the **Battery Info** item, you can view the battery power, day discharged and charged, as shown in Figure4-14.

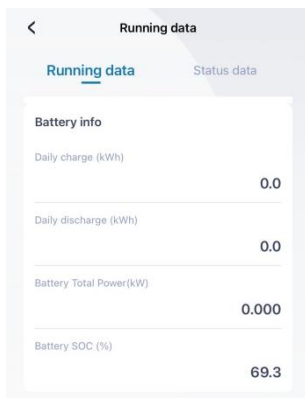

Figure4-14 Battery info page

Load info

In the **Load Info** item, you can view the load voltage of L1/L2, load power and frequency, etc., as shown in Figure4-15.

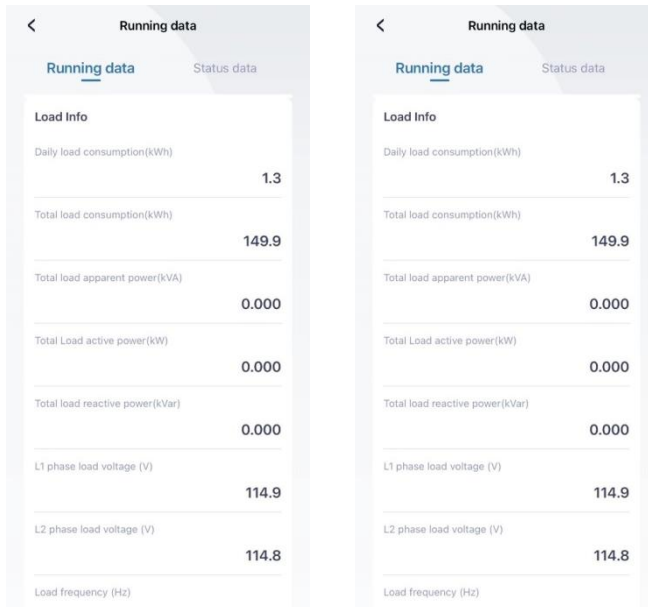

Figure4-15 Load info page

PV info

In the **PV Info** item, you can view the voltage, current, power of PV1/PV2/PV3/PV4 and day energy of PV, etc., as shown in Figure4-16.

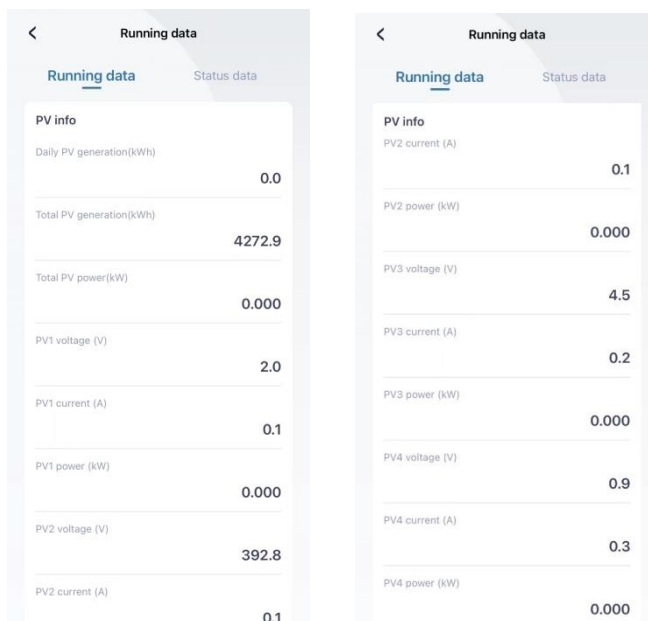

Figure4-16 PV info page

Generator information

In the **Generator information** item, you can view generator or solar inverter current and voltage information etc., as shown in Figure4-17.



The screenshot shows a mobile application interface with a 'Running data' section. Under 'Generator Information', the following data is displayed:

Parameter	Value
Daily Gen generation (kWh)	0.0
Total Gen generation (kWh)	0.0
Generator apparent power(kVA)	0.000
Generator active power(kW)	0.000
Generator reactive power(kVar)	0.000
L1 phase generator voltage (V)	9.6
L2 phase generator voltage (V)	9.5
Generator frequency (Hz)	0.00

Figure4-17 Generator information page

Device info

In the **Device Info** item, you can view the device S/N, software version and PV quantity, battery pack quantity etc., as shown in Figure4-18.

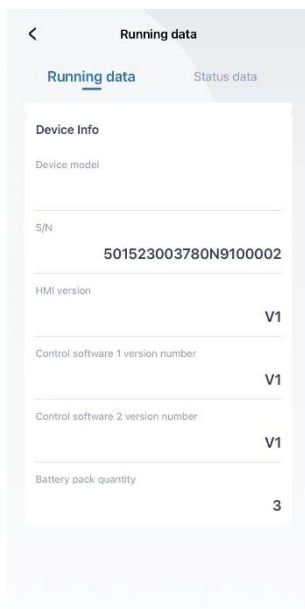

The screenshot shows a mobile application interface with a 'Running data' section. Under 'Device Info', the following data is displayed:

Parameter	Value
Device model	
S/N	501523003780N9100002
HMI version	V1
Control software 1 version number	V1
Control software 2 version number	V1
Battery pack quantity	3

Figure4-18 Device info page

Battery pack 1/2/3/4

In corresponding **Battery pack 1/2/3/4** page, you can view the S/N, software version, BMU version, hardware version, battery power, etc. of battery pack, as shown in Figure4-19.

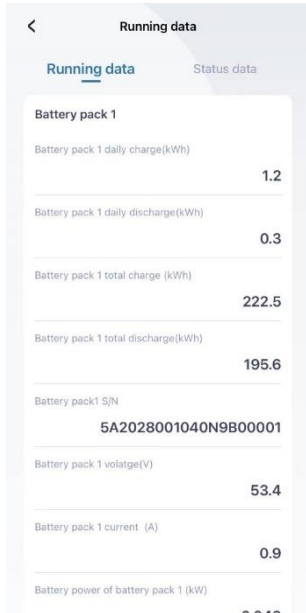

Figure4-19 Battery pack info page

NOTE

The address of battery pack (address is 1, 2,3,4,5....) can be set through APP according to needs.
The setting is in the operation & maintenance authority and needs to be set by installer.

4.3.2 Status Data

The **Status** page includes running status, charge & discharge status of battery pack 1/2/3/4, as shown in Figure4-20.

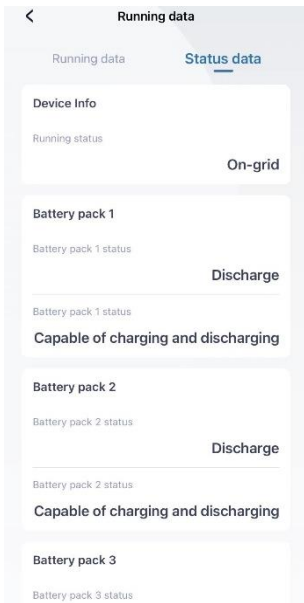

Figure4-20 Status info

4.4 Indicator light and Alarm query

The indicator light shows the status of ATG-ST-H01 series in device information page. Green indicates

that the system is running properly and Red indicates that an alarm is generated. Tap the Inverter icon to show the detailed alarm, as shown in below.



Figure4-21 Indicator light

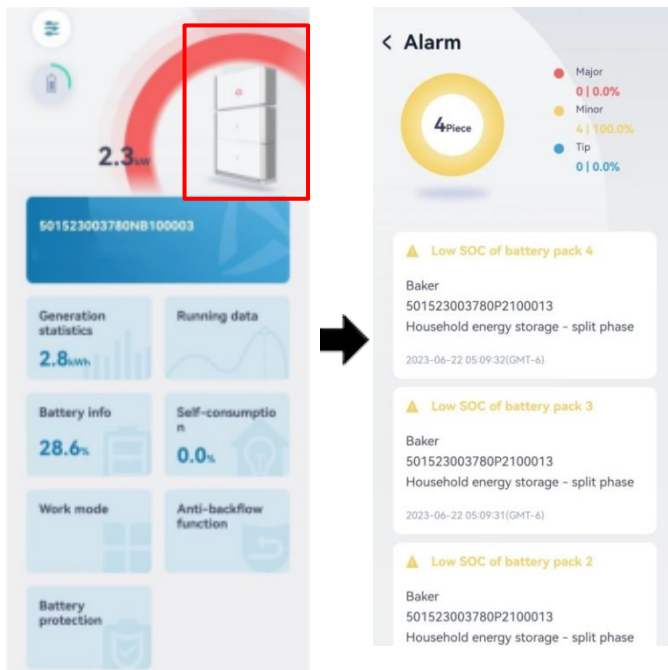

Figure Detail alarm

4.5 Device Control

Back to previous page from running data, tap the left  icon, it will enter control page, as shown in below.



Figure4-22 Details page

 **NOTE**

When setting, the password is required. The password is the login password.

4.5.1 Grid Setting

In the **Grid setting** page, you can set the grid level I under-voltage protection value, as shown in below.

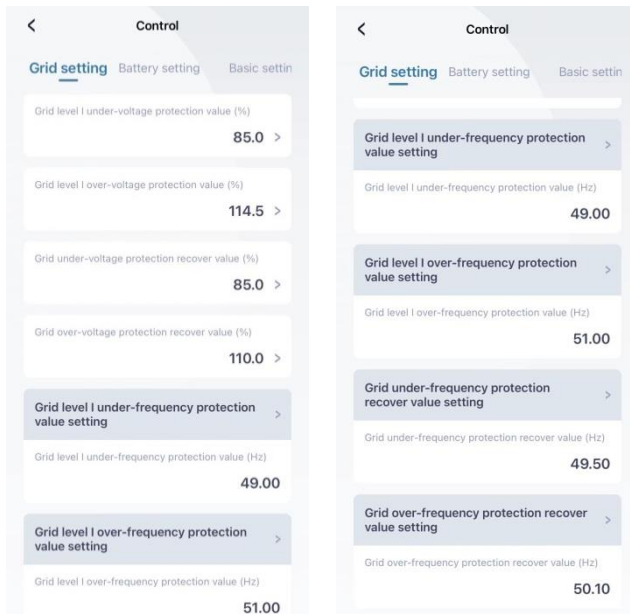

Figure4-23 Grid setting page

Table4-1 Grid setting illustration

Item	Illustration
Grid level I under-voltage protection value(%)	The minimum grid voltage available
Grid level I over-voltage protection value(%)	The maximum grid voltage available
Grid under-voltage protection recover value(%)	When the grid voltage increase to this value, the system will resume
Grid over-voltage protection recover value(%)	When the grid voltage decreases to this value, the system will resume
Grid level I under-voltage	Operating time available in Grid level I under-voltage

Item	Illustration
protection time setting	
Grid level I over-voltage protection time setting	Operating time available in Grid level I over-voltage
Grid level I under-frequency protection value setting	Operating frequency available in Grid level I under-frequency
Grid level I over-frequency protection value setting	Operating frequency available in Grid level I over-frequency
Grid level I under-frequency protection time setting	Operating time available in Grid level I under-frequency
Grid level I over-frequency protection time setting	Operating time available in Grid level I over-frequency

4.5.2 Basic Setting

In the **Basic setting** page, you can set the ON/OFF, external control mode and auto-start when power on, etc., for the device, as shown in below.

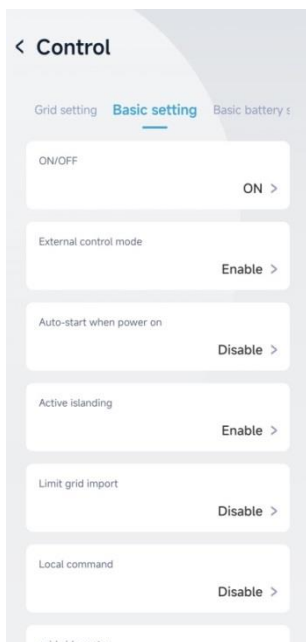

Figure4-24 Basic setting page

The illustration for the setting in the **basic setting** page is as follows.

Table4-2 Illustration for the setting in the basic setting page

Item	Illustration
ON/OFF	Turn ON/Turn OFF the system
External control mode	The item is used to enable or disable the external control mode.
Auto-start when power on	The item is used to select whether to auto start when power on. When the function is enabled, once the device has power source (PV or grid), it will be started automatically.
Active islanding	This item is used to select whether to enable the active islanding function. When the function is enabled, if the device stays in islanding status, it will disconnect the connection with grid automatically.
*Reset settings	Reset system
Weather mode	The item is used enable the weather mode. The weather mode includes Storm mode and Economy mode.

4.5.3 Battery Setting

In the **Basic battery settings** page, the battery charge & discharge power can be set, as shown in below.

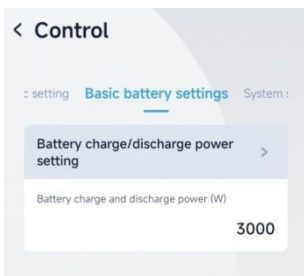

Figure4-25 Basic battery settings page

The illustration for the setting in the **basic setting** page is as follows.

Table4-3 Illustration for the setting in the basic setting page

Item	Illustration
Battery charge and discharge	Battery charge and discharge power setting is valid only when battery

Item	Illustration
power setting	power first at the external control mode.

4.5.4 System Setting

In the **System setting** page, you can view the quantity of battery pack and system time, as shown in below.

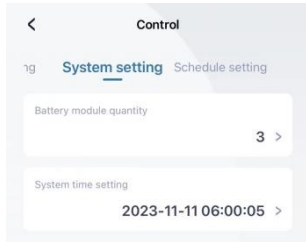

Figure4-26 System setting

NOTE

The illustration for the setting in the **basic setting** page is as follows.

Table4-4 Illustration for the setting in the basic setting page

Item	Illustration
Battery module quantity	The battery pack quantity and system time cannot be changed by user manually.
System time setting	The item is used to set the system time.

4.5.5 Schedule Setting

In the **Schedule setting** page, the power control mode, work mode, SOC threshold of discharge ending, etc. can be set, as shown in below.

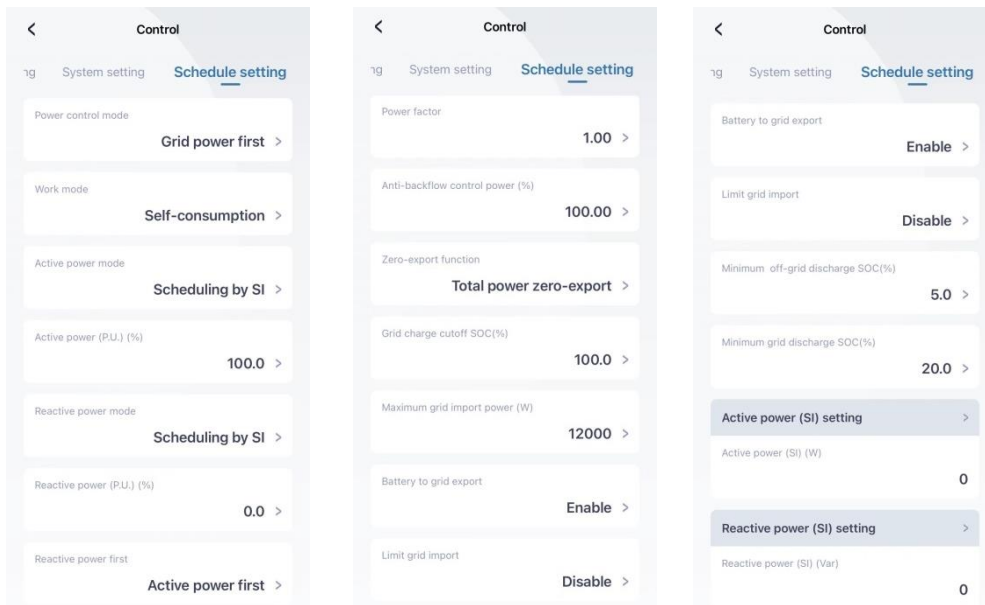

Figure4-27 Schedule setting

The illustration for schedule setting is as follows.

Table4-5 Illustration for schedule setting

Item	Illustration
Power control mode	This item is used to select the battery first or grid first mode. This item is only available for external control mode, for other modes, it is invalid.
Work mode	This item is used to select the work mode of device. After setting, when the device stays in corresponding time, it will perform corresponding action.
Active power mode	This item is used to select the output power scheduled by SI or P.U.
Active power (P.U.) (%)	This item is just available for external control mode, for other modes, it is invalid.
Reactive power first	This item is just available for external control mode, for other modes, it is invalid. This item is used to select the inverter output power is to satisfy the reactive power first or active power first.
Power factor	This item is just available for external control mode, for other modes, it is invalid. The proportion of active power in total power

Item	Illustration
Zero-export control power (%)	It ensures that energy flows in one direction and prevents it from flowing backward.
Zero-export function	Enable or disable the Zero-export function. When the local laws and regulations do not allow discharging for grid, the function can be enabled.
Grid charge cutoff SOC(%)	The item is set the battery charge cut-off SOC when system stop charging battery..
Maximum grid import power(W)	This item is just available for limit grid import mode, for other modes, it is invalid. It's a value for limiting maximum grid power from grid.
Battery to grid export	This item is just available for Time of use mode, for other modes, it is invalid. It is used for making the battery energy to grid.
Limit grid import	This item is just available for limit grid import mode, for other modes, it is invalid. It is used for enable the function of limiting maximum grid power from grid.
Minimum off-grid discharge SOC (%)	The item is set the battery discharge SOC when system work in off-grid mode
Minimum grid discharge SOC (%)	The item is set the battery discharge SOC when system work in on-grid mode
Active power (SI) setting	User can set the active power of grid-tied manually. The setting can be take effect only under the circumstance of the external control mode- grid power first.
Reactive power (SI) setting	User can set the reactive power of grid-tied manually. The setting can be take effect only under the circumstance of the external control mode- grid power first.

**NOTE**

You need to enter a password to configure advanced functions.

4.6 Generation statistics

Tap **Generation statistics** to display daily generation curve, as shown in below.



Figure4-28 Generation statistic page

At the bottom of the page, you will view the Week, Month, Year even Total data, as shown in below.

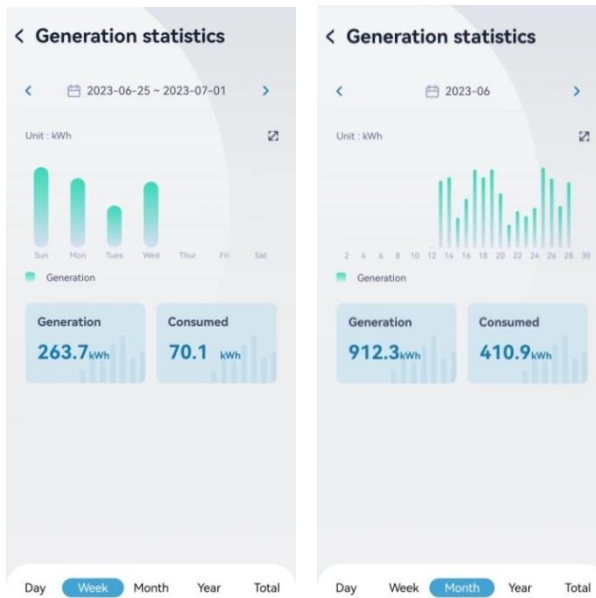

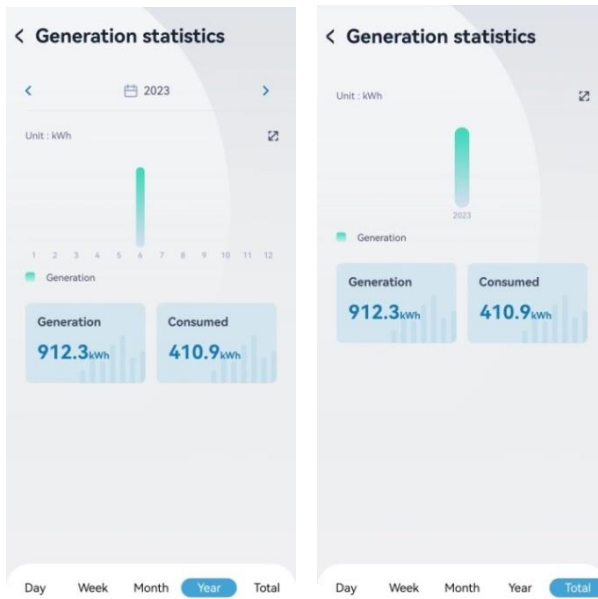

Figure4-29 Week Month Year Total data

4.7 Battery Info

In the **Battery Info** item, you can view the **Battery Overview** containing **Day charged**, **Day discharged**, **Total charged** and **Total discharged**. At the top, you can select battery 1 to 4 for details, as shown in below.

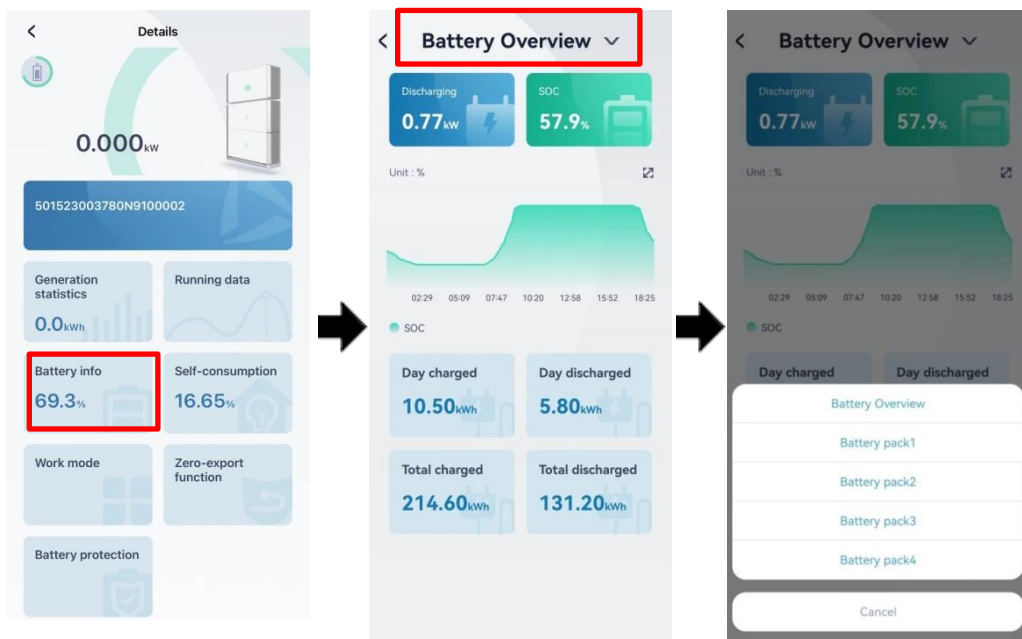

Figure4-30 Battery info page

4.8 Self-consumption

In the **Battery Info** item, you can view the **Self-consumption rate** and **Self-supply rate**, as shown in below.

 **NOTE**

Self-consumption rate means the rate of load energy come from solar.

Self-supply rate means the rate of solar energy give to the load.



Figure 12 Self-consumption page

4.9 Work mode

In the **Work mode** item, you can select work mode and in details you can view the introduction of work mode, as shown in below.

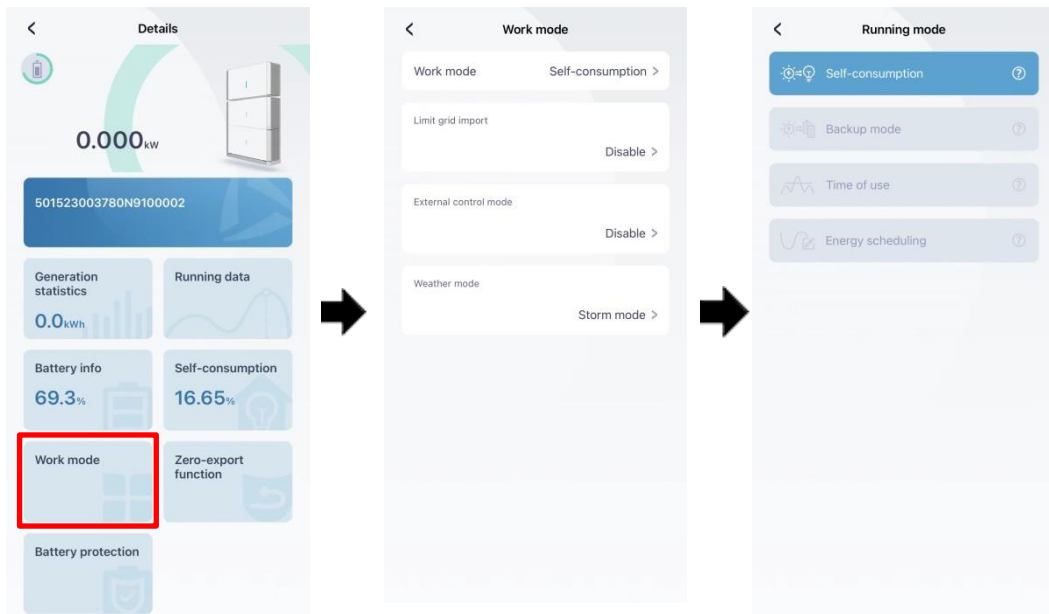

Figure4-31

Self-Consumption function setting

In this mode, the PV generated energy is supplied to load, and the remainder power is used to charge battery or supply to grid.

Step 1 Enter the **Work mode** and select **Self-Consumption**

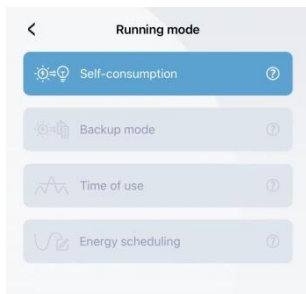

Figure 14 Self-Consumption page

Backup mode function setting

In this mode, the PV generation is supplied to battery, and the remainder power is supplied to load, and when the electricity demand cannot be met, the energy will be supplied by grid.

Step 1 Enter the **Work mode** and select **Backup mode**

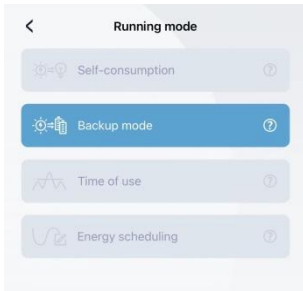

Figure4-32 "Backup mode" page

Time of use function setting

In this mode the self-generation and self-consumption strategy is used during peak period, and the backup mode is used during valley period, while the battery does not working during others hours, and the energy consumption demand is met by PV generated and grid.

- Step 1 Enter the **Work mode** and select **Time of use**.
- Step 2 Turn on or turn off **Fully to grid**. When the you turn on the **Fully to grid**, the device will support the energy of max power to load and grid in the peak time.
- Step 3 Select Workday or Weekend, and set Peak Period and Vally Period.

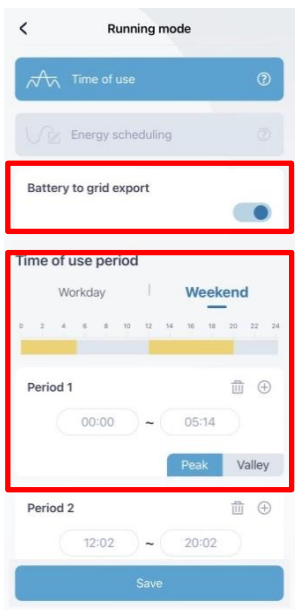

Figure4-33 Time of use page

Energy Scheduling function setting

In this mode, the battery is charged at full power during charging time, discharged at full power during discharge time, and not charged or discharged during other period.

Step 1 Enter the **Work mode** and select **Energy scheduling**.

Step 2 Select Workday or Weekend, and set Charge Period and Discharge Period.

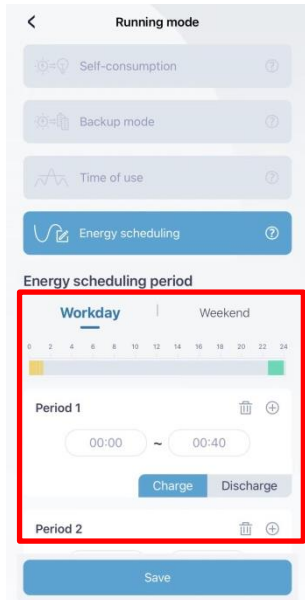

Figure4-34 "Energy Scheduling" page

4.9.2 Limit grid import function setting

This function will limit the power from the grid.

Step 1 Select the **Limit grid import**.

Step 2 Enable the **Limit grid import**.

Step 3 Enter the Maximum grid import power.

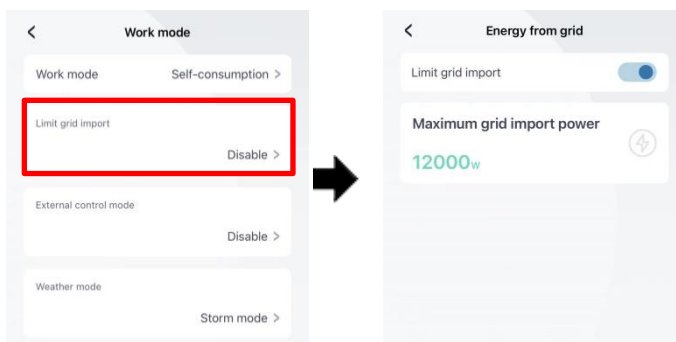

Figure4-35 Enable power limit from grid setting page

4.9.3 External control mode function setting

External control mode function is used for VPP function, If you do not use this function, you can disable it in normal times.

- Step 1 Select the External control mode.
- Step 2 Enable the External control mode.
- Step 3 Set specific information.

After setting, when the device stays incorresponding time, it will perform corresponding action according external demand.

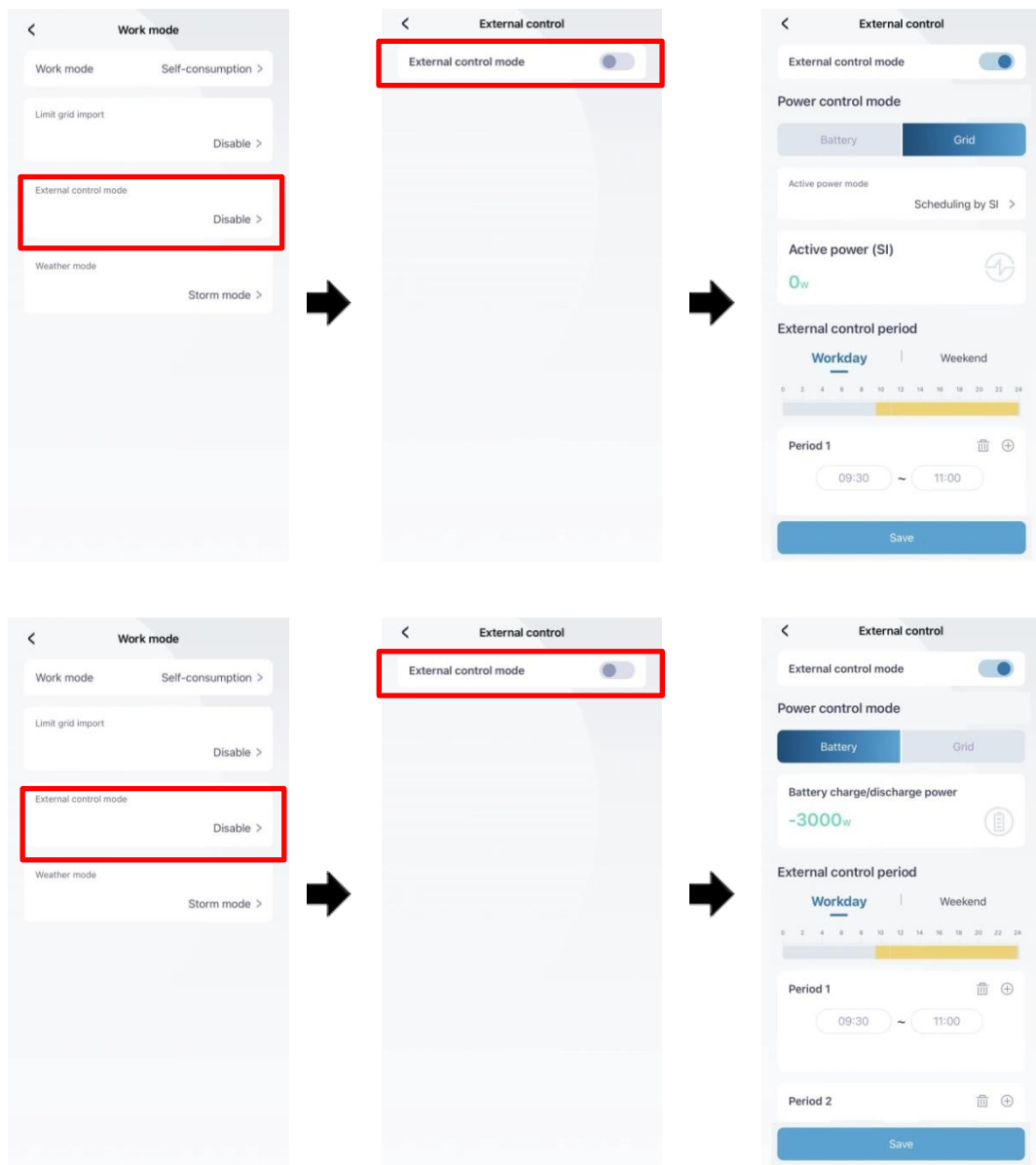

Figure4-36 "External control mode" setting page

4.9.4 "Weather mode" function setting

The **weather mode** includes **Storm mode** and **Economy mode**.

Storm mode

Effectively manage backup energy based on storm warning information to ensure electricity demand.

Economy mode

Optimize charging and discharging strategies to improve electricity efficiency based on future weather conditions. If you close the weather mode, the device does not enforce weather mode-related policies.

Step 1 Select the **Work mode**.

Step 2 Select **Storm mode** or **Economy mode** or **Close** in **weather mode**, as shown in Figure .

Step 3 If you choose the **Economy mode**, it need to set the like **Time of Use** according to as shown in below.

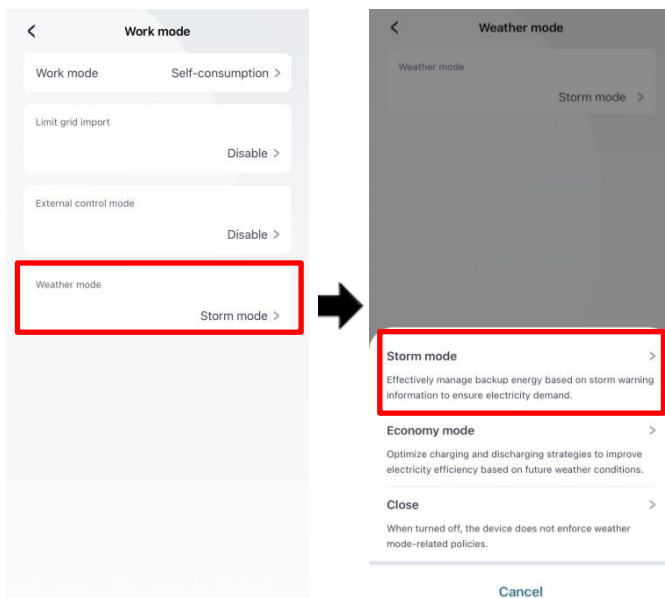

Figure4-37 Weather mode choose page

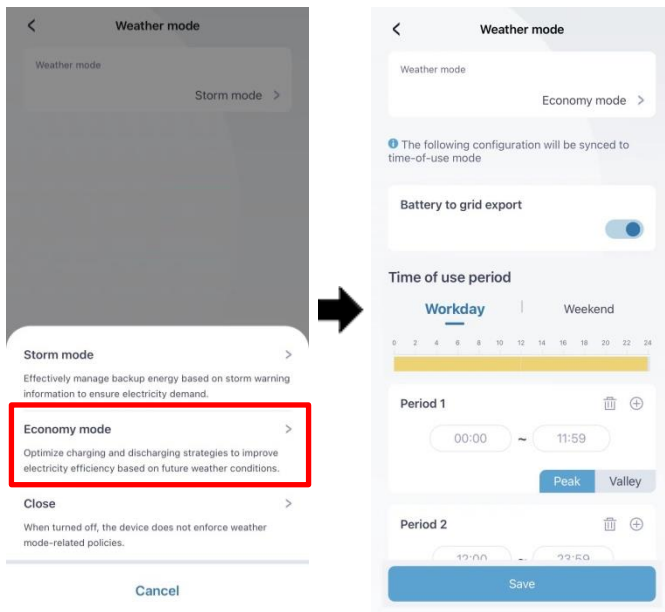

Figure4-38 Economy mode configuration page

4.10 Zero-Export Function

In the **zero-export function** item, you can set zero-export function type Zero-export control power, as shown in below.

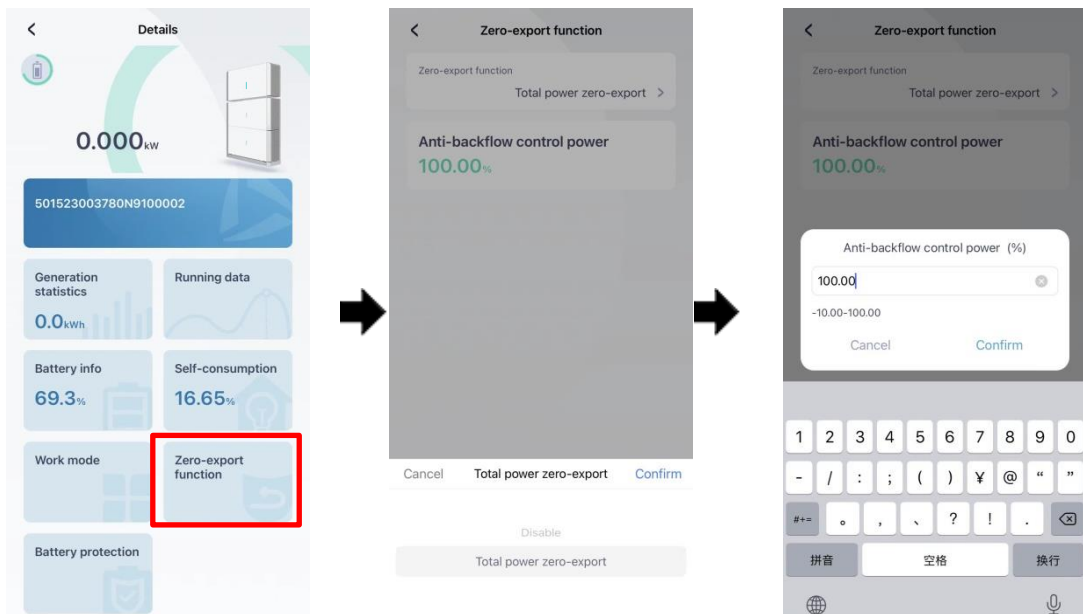

Figure4-39 Zero-export function page

4.11 Battery protection

In the "Battery protection" item, you can set charge ending SOC and discharge ending SOC, as shown in below.

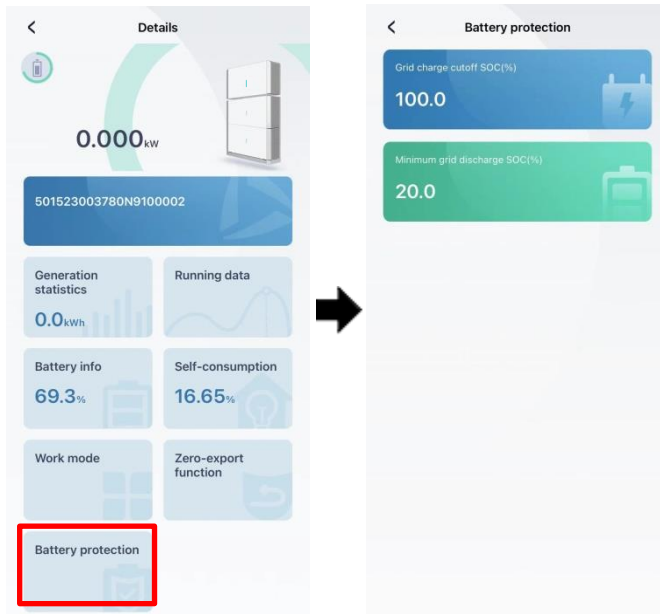

Figure4-40 Battery protection page

4.12 ON/OFF

In the **Battery protection** item, you can set charge ending SOC and discharge ending SOC, as shown in below.

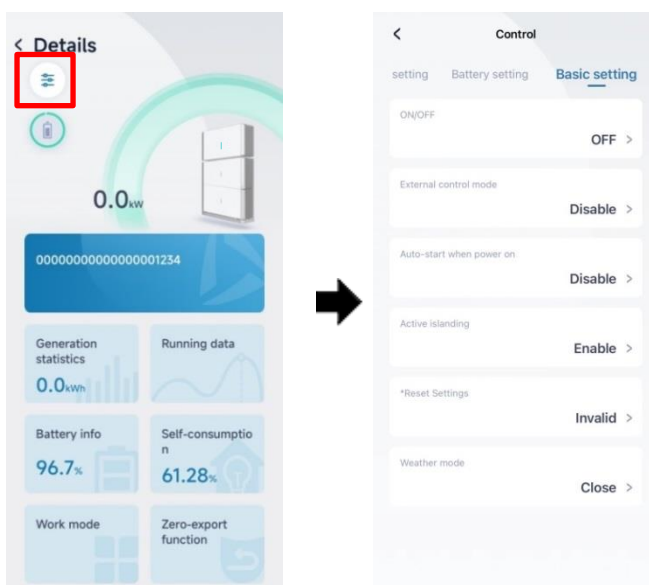

Figure4-41 Battery protection page

4.13 Agent Configuration

4.13.1 Agent Management

The agent can apply for an account. It could help agent know the user system running status. It also has higher rights to set some system functions for avoiding system errors caused by user wrong operation. The agent can search the user's system, as shown in below.

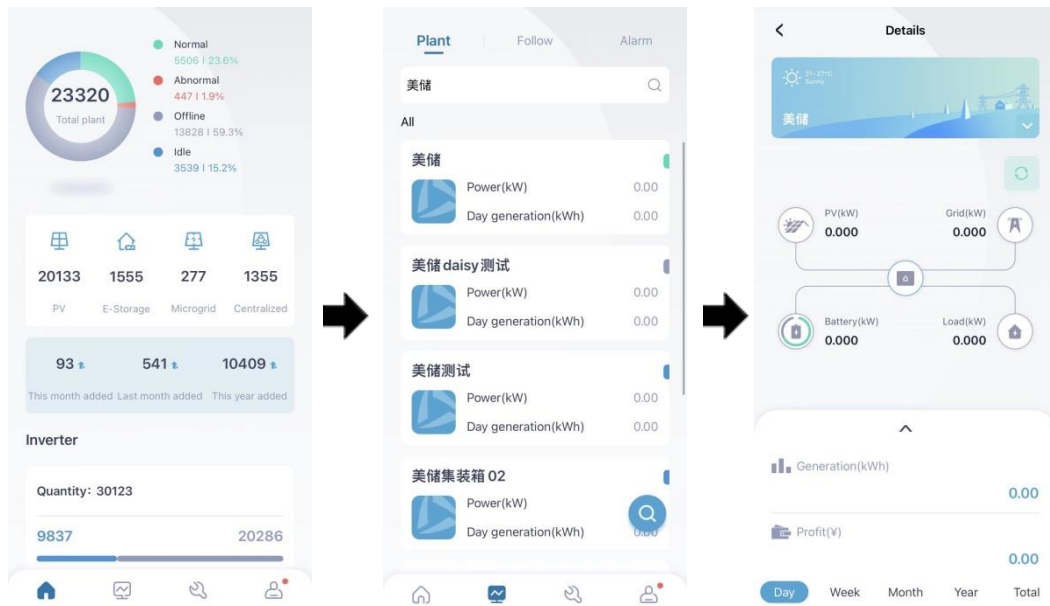

Figure4-42 Battery protection page

NOTE

User's WIFI module need to associate the agent, otherwise agent could not find the relevant information.

4.13.2 General function configuration

In the system, we need to set the **Grid side meter and Battery module quantity according to system diagram.**

- Step 1 Tap the Function setting icon.
- Step 2 Choose the Basic setting, select Grid side meter and set according to Table xxxx, then set the Battery module quantity according to battery module number, as show in below.

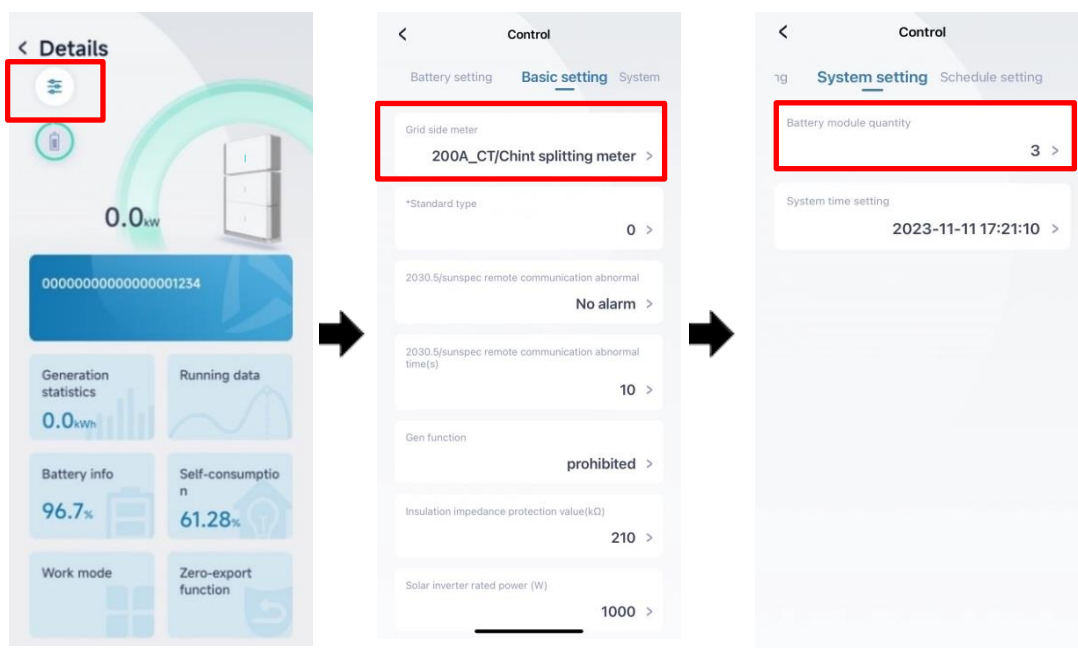

Figure4-43 Battery protection page

Table4-6 Grid side meter configuration

System diagram	Grid side meter
System diagram 2/System diagram 5	200A_CT/Chint Splitting phase meter

4.13.3 Gen. Function (Solar Inverter Access) Configuration

If a solar inverter is connected to the system, we need to set the **Gen.function** for solar inverter, as shown in below.

- Step 1 Enter Gen.function and choose Photovoltaic inverter.
- Step 2 According to Table and set the **Grid side meter** item.
- Step 3 Set the AC couple **Solar inverter rated power**.

NOTE

The solar inverter rated power should be set by APP when the system is installed to ensure that the system grid port output is not overloaded.

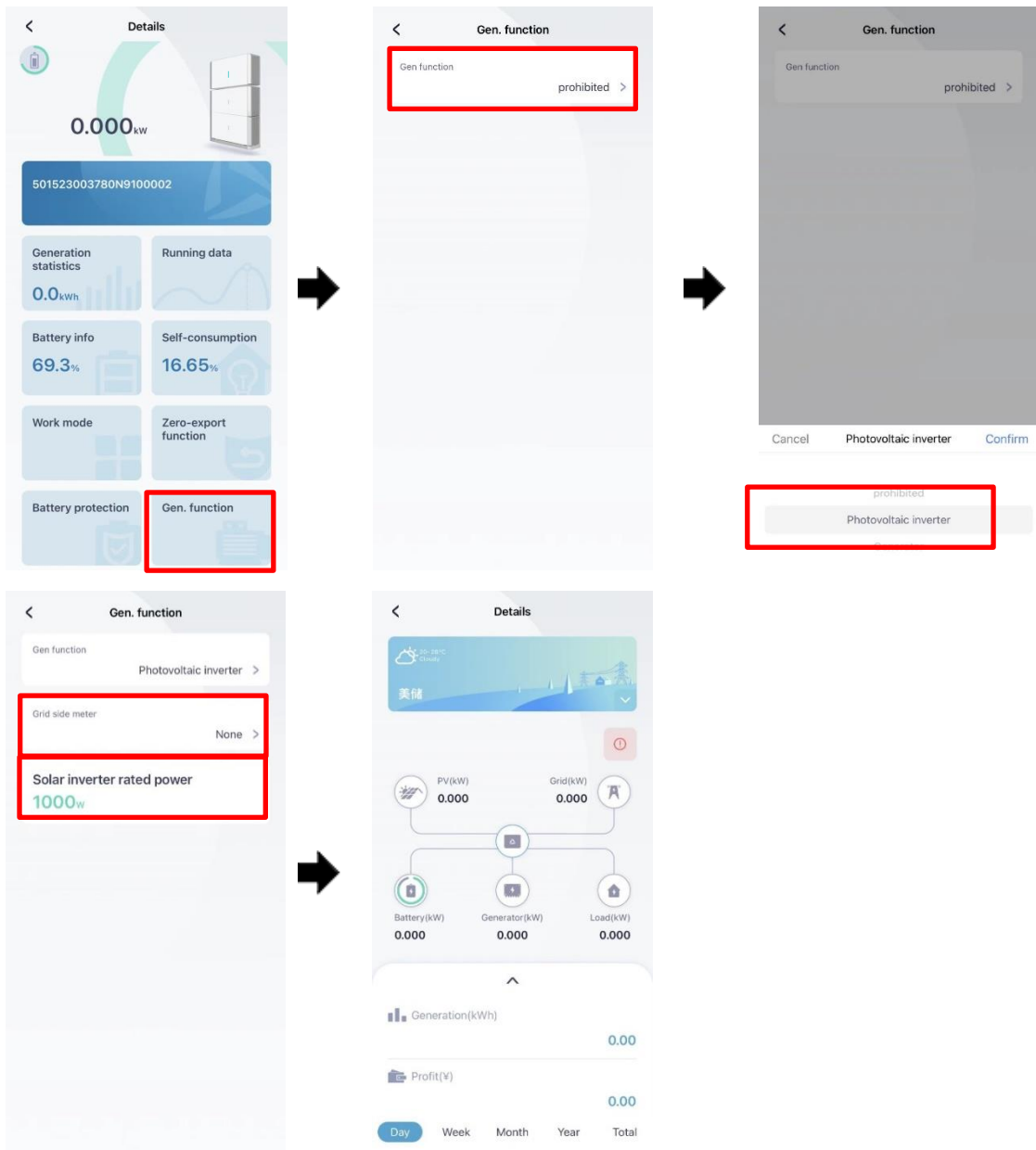

Figure4-44 solar inverter access setting

Table4-7 Grid side meter setting when solar inverter access

System diagram	Grid side meter
System diagram 2/System diagram 5	200A_CT/Chint Splitting phase meter

4.14 Gen. Function (Generator Access) Configuration

If a generator is connected to the system, we need to set the **Gen. function** for generator, as shown in below.

- Step 1 Enter **Gen.function** and choose **Generator**.
- Step 2 According to Table and set the **Grid side meter** item.
- Step 3 Set the **Maximum gen to battery power**.

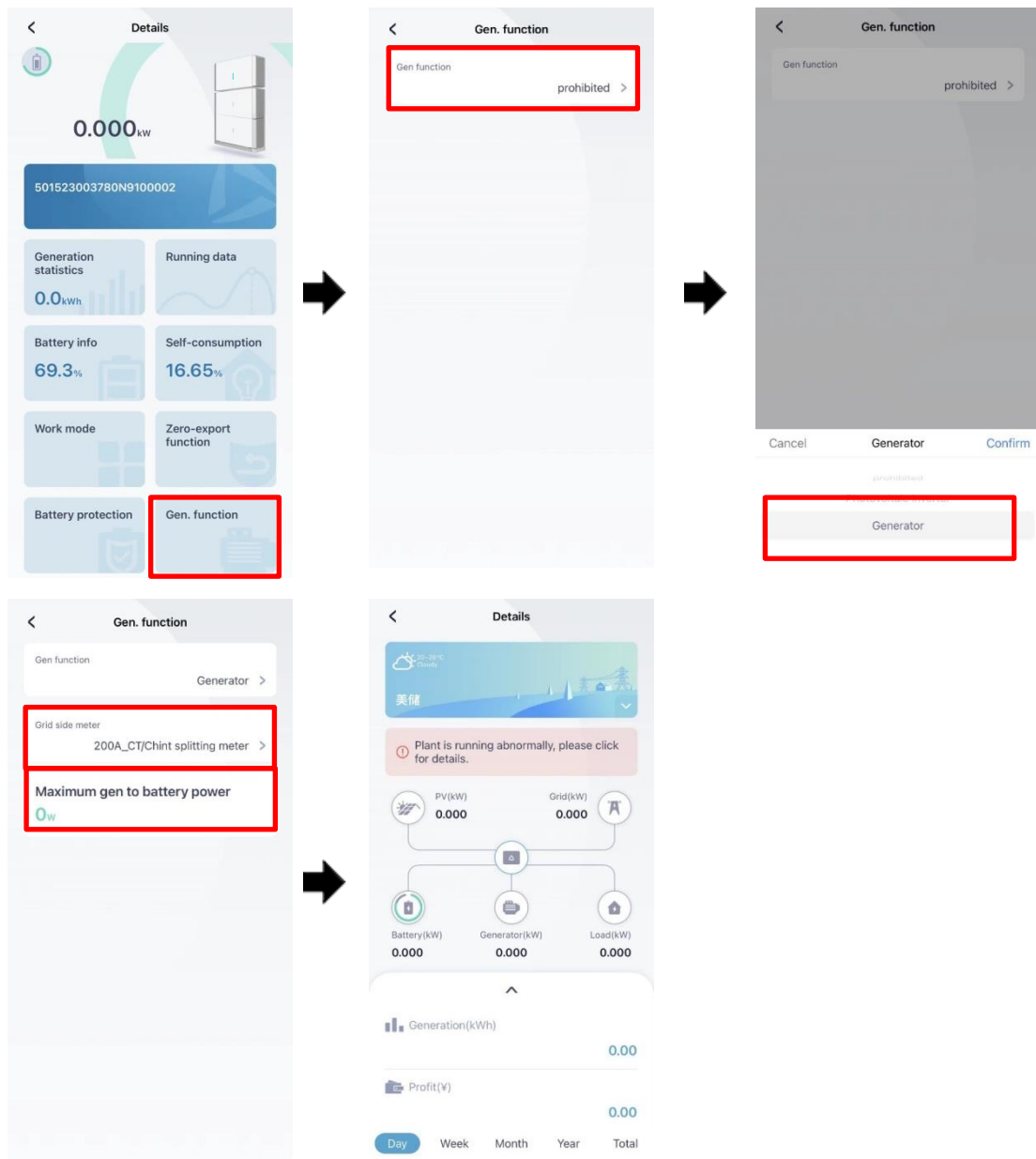

Figure4-45 Generator access setting

Table4-8 Grid side meter setting when generator access

System diagram	Grid side meter
System diagram 3/System diagram 6	200A_CT/ Chint Spliting phase meter

4.15 Distribution Box Configuration

If distribution box is connected to the system, we need to enable the, as shown in below.

Step 1 Enter the **Function setting**.

Step 2 Choose the **Basic setting** and enable the backup box.

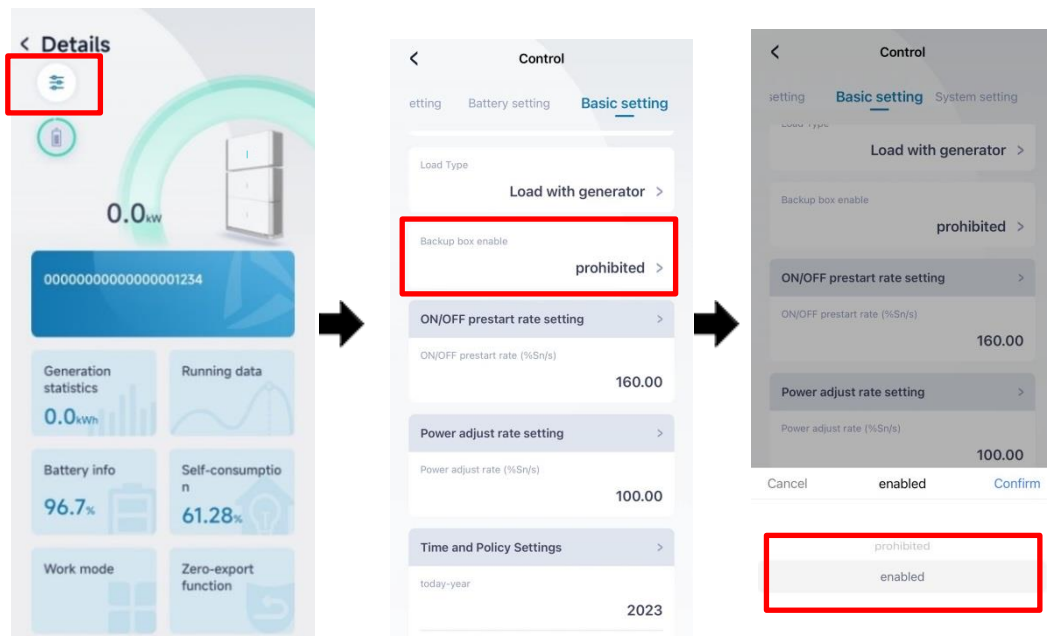

Figure4-46 Generator access setting

5 Startup and Shutdown

5.1 Startup

- Step 1 Check the system wiring is correct.
- Step 2 Turn on the DC switch, external AC breaker. Long press Battery module power button on each battery about 5s.
- Step 3 Build the plant through the APP, please refer to 4.1 First Startup for details.
- Step 4 Before start the ATG-ST-H01 series, you should set the ATG-ST-H01 series via APP. You need to configure different contents according to different system diagram.
- Step 5 The user sets the mode according to the household electricity consumption, according to 4.9 Work mode.
- Step 6 After setting, turn on the ATG-ST-H01 on the APP.
- Step 7 When the DC and AC supply power normally, the hybrid inverter will prepare to start, 60s later, the system operates normally, or checking the insulation impedance.
- Step 8 About 60s, the hybrid inverter will generate power normally. LED is always on.
- Step 9 Working status can be queried on the APP.

---End



When the system is powered on for the first time or has not been used for a long time, the battery module SOC may have a large difference, at which time the battery module will automatically recalibrate SOC.

For the first using, the battery module needs to be fully charged in backup mode to calibrate multiple batteries SOC.

In the case of no grid and PV, if there is no power supply for the hybrid inverter and battery module, you need to press and hold the battery module start button for more than 5s to let the battery module supply power to the hybrid inverter and let the whole system run normally.

 **NOTE**

- Off-grid function verification

When the device is running normally, disconnect the grid side breaker, the device can run normally in off-grid status, and then close the grid breaker, the device can be connected to the grid normally.

- RSD function verification

When the PV is generating electricity normally, press the RSD knob to check the PV voltage of the device, and then release the RSD knob, the device can be connected to the grid normally.

5.2 Shutdown

Step 1 Power off the hybrid inverter on the APP.

Step 2 Switch off the PV switch, external AC breaker, wait for the hybrid inverter indicator light to be off.

Step 3 Press all battery module **POWER** button twice continuously, the battery module indicator light will turn off.

 **NOTE**

After powering off the system by pressing the power button, if you need to power on the battery again, please shut down the system through APP, and then long press the power button 5s to start the battery.

If the battery module needs to be shut down or started independently, please perform the follow operation.

- Shut down the battery module:

- When the PV has power, the battery module won't be power down.

- When the PV without voltage and grid has power, it is necessary to press the POWER button twice and wait for a while, press the POWER button twice again, and then the battery module will be power down.

- When only the battery module is used for power supply, press the POWER button twice continuously, the battery module will be shut down.

- Start the battery module:

Press the POWER button of battery module for 1s, the indicator on the hybrid inverter light on, long press the POWER button for 5s, the battery can be started.

----End

6 Maintenance and Troubleshooting

This chapter mainly introduces the maintenance and troubleshooting for device.

6.1 Maintenance

The energy storage system ATG-ST-H01 series needn't to be maintained regularly, but the sundries or dust may influence the heat dissipation performance, so, use soft brush to clean the hybrid inverter. If the LED indicator is too dirty to view, use a wet cloth to clean them.



During running, do not touch the hybrid inverter. The temperature of some parts on the hybrid inverter is too high, and may cause scald injury. After shut down the hybrid inverter and wait until it cooling down, then do the maintenance and clean.



Do not clean the hybrid inverter with any solvent, abrasive material or corrosive material.

Normally, the hybrid inverter and battery module need no maintenance or calibration. However, in order to maintain the accuracy of the SOC, it is recommended to perform a full charge calibration for SOC (charging battery module until the charging power is 0) on the battery module at regular intervals (such as two weeks).

Disconnect the hybrid inverter and battery module from all power sources before cleaning. Clean the housing, cover and display with a soft cloth.

To ensure that the hybrid inverter and battery module can operate properly in the long term, you are advised to perform routine maintenance on it as described in this chapter.

Table6-1 Maintenance checklist

Check Item	Acceptance Criteria	Maintenance Interval
Product cleanliness	The heat sink of the hybrid inverter is free from obstacles or dust.	Semiannually or once per year
Product visible damage	The hybrid inverter and battery module are not damaged or deformed.	Semiannually
Product running status	<ol style="list-style-type: none"> 1. The hybrid inverter and battery module operate with no abnormal sound. 2. All parameters of the hybrid inverter and battery module are correctly set. Perform this check when the hybrid inverter and battery module is running. 	Semiannually
Electrical connections	<ol style="list-style-type: none"> 1. Cables are securely connected. 2. Cables are intact, and in particular, the cable jackets touching the metallic surface are not scratched. 3. Unused PV input terminals, unused communication ports of the hybrid inverter, power and COM terminals of the battery module are locked by watertight caps if the product is mounted outdoor. 	The first maintenance is needed 6 months after the initial commissioning. And then make it semiannually or once per year.

CAUTION

Before maintenance, the DC switch must be OFF, and 5 minutes after the indicator is off, the maintenance can be done.

When maintenance or wiring, the DC switch must be disconnected.

6.2 Troubleshooting

The hybrid inverter is designed on the basis of the grid-tied operation standards and meets the requirements of safety and EMC. Before provided to client, the hybrid inverter has been experienced for several rigorous tests to ensure reliable and optimizing operation. The troubleshooting is as shown in Table6-2.

Table6-2 Hybrid inverter troubleshooting

Check item	Fault description	Solution
Grid over-voltage	Grid voltage exceeds the allowable range.	<ol style="list-style-type: none"> 1. Check whether the grid is normal. 2. Check whether the wiring of grid is normal. 3. Restart the hybrid inverter to see if the fault still exists. If it still exists, contact service.
Grid under-voltage	Grid voltage exceeds the allowable range.	<ol style="list-style-type: none"> 1. Check whether the grid is normal. 2. Check whether the wiring of grid is normal. 3. Restart the hybrid inverter to see if the fault still exists. If it still exists, contact service.
Grid over-frequency	Grid frequency exceeds the allowable range.	<ol style="list-style-type: none"> 1. Check whether the grid is normal. 2. Check whether the wiring of grid is normal. 3. Restart the hybrid inverter to see if the fault still exists. If it still exists, contact service.
Grid under-frequency	Grid frequency exceeds the allowable range.	<ol style="list-style-type: none"> 1. Check whether the grid is normal. 2. Check whether the wiring of grid is normal. 3. Restart the hybrid inverter to see if the fault still exists. If it still exists, contact service.
Generator abnormal	Generator amplitude or frequency exceeds the allowable range.	<ol style="list-style-type: none"> 1. Check whether the wiring of generator is normal. 2. Check whether the power of load is normal 3. Restart the generator and tested after removing a portion of the load to see if the fault still exists. If it still exists, contact service.

Check item	Fault description	Solution
Short-circuit protection	When off-grid, the output side is short-circuited	<ol style="list-style-type: none"> 1. Measure the output side impedance by multimeter. If the impedance is small, please check whether the wiring of grid is right. 2. Restart the hybrid inverter to see if the fault still exists. If it still exists, contact service.
Overload protection	Load is too heavy.	<ol style="list-style-type: none"> 1. Check whether the load exceeds the rated power. 2. Restart the hybrid inverter to see if the fault still exists. If it still exists, contact service.
Inverter over-current	The current of hybrid inverter exceeds the allowable value	<ol style="list-style-type: none"> 1. Check whether the off-grid output is overloaded, short circuited or has impact load. 2. Restart the hybrid inverter to see if the fault still exists. If it still exists, contact service.
Inverter voltage abnormal	Output voltage abnormal	Check whether voltage and load of grid is abnormal.
Inverter voltage DC component abnormal	When off-grid, voltage DC component abnormal.	Restart the hybrid inverter to see if the fault still exists. If it still exists, contact service.
Inverter current DC component abnormal	When grid-tied, current DC component abnormal.	Restart the hybrid inverter to see if the fault still exists. If it still exists, contact service.
DC bus over-voltage	Bus voltage is too high.	<ol style="list-style-type: none"> 1. Check whether the max. input voltage of PV1, PV2, PV3, PV4 exceed 500V. 2. If the item 1 is OK, restart the hybrid inverter to see if the fault still exists. If it still exists, contact service.
DC low power	Insufficient power on DC side to load	<ol style="list-style-type: none"> 1. Check if the power grid is normal; 2. Make sure the battery power and PV power are less than the load power; 3. Restart after disconnecting the load

Check item	Fault description	Solution
Insulation impedance abnormal	The impedance on DC side to ground is too low.	<ol style="list-style-type: none"> 1. If the fault occurs when power on in the morning, it may be caused by wet weather. 2. Use a multimeter to measure the impedance of the ground to the housing. If the impedance is not close to 0, it is connection problem between the ground wire and the housing. 3. Measure the impedance of ground to PV1+/PV2+/ PV3+/PV4+/PV- by multimeter. If the impedance is less than 208kΩ, check whether the connection of each port is correct. 4. Confirm to install the device according to the user manual. 5. Restart the hybrid inverter to see if the fault still exists. If it still exists, contact customer service.
Residual current abnormal	Residual current exceeds allowable range.	Restart the hybrid inverter to see if the fault still exists. If it still exists, contact customer service.
Device over-temperature	Temperature is too high and reaches the rated drop point.	<ol style="list-style-type: none"> 1. Check whether the environment temperature is too high, try to lower the ambient temperature. 2. Make sure that the hybrid inverter is installed according to the manual and there is no block around the hybrid inverter. 3. After the hybrid inverter is powered off and waiting for 30 minutes, then restart it. If the fault still exists, contact service.
Fan abnormal	Fan abnormal	<ol style="list-style-type: none"> 1. Check whether the fan is blocked. 2. Restart the hybrid inverter to see if the fault still exists. If it still exists, contact customer service.
RSD active	RSD enable	Confirm whether there is a fire in the PV array, if

Check item	Fault description	Solution
		so, you need to manually press the RSD button and manually rotate the RSD button back after the fire; If you are not sure about the fault, please contact customer service.
Remote communication abnormal	Cannot communicate with upper computer.	<ol style="list-style-type: none"> 1. Confirm whether the baud rate and address is correct. 2. Confirm if the wire from the device to PC is normal.
Smart meter abnormal	Meter communication wire wiring abnormal	<ol style="list-style-type: none"> 1. Confirm that the meter is wired according to the manual; 2. Confirm that the A and B interfaces of the meter are wired correctly according to the manual; 3. Check the meter communication address, baud rate, parity bit
Inner abnormal	The inner of the hybrid inverter is abnormal	<ol style="list-style-type: none"> 1. Confirm whether the inner of the hybrid inverter is abnormal on the basic of the related fault info. 2. Restart the hybrid inverter to see if the fault still exists. If it still exists, contact customer service.
Upgrading	The program is being upgraded.	<ol style="list-style-type: none"> 1, Confirm whether the program is upgrading, if so, wait for the alarm to disappear; 2, If not upgraded, restart the system
Battery quantity abnormal	The number of batteries (set on the app) does not match the actual number of batteries installed	Detect the actual number of batteries installed and set the number to match the number of battery modules on the APP. After setting, restart the system.
Weather mode running	Weather mode is running	Enable the weather mode and operate according to the weather mode.

Check item	Fault description	Solution
Arm to Arc communication abnormal	Arc communication board abnormal	1. Restart the hybrid inverter to see if the fault still exists. If it still exists, contact customer service.
Unit communication line abnormal	Abnormal communication with the battery pack	1, Check whether the actual number of online battery packs is the same as the number of battery packs set on APP; 2, Check the wiring between the battery pack and the inverter to see if the wiring is abnormal; 3, Restart the hybrid inverter to see if the fault still exists. If it still exists, contact customer service.
PCS communication line abnormal	Communication abnormal	1. Restart the hybrid inverter to see if the fault still exists. If it still exists, contact customer service.
PV1 wire abnormal	The positive and negative of PVn input is reversed.	Check whether the wiring of PVn is reversed.
PVn over-voltage	The voltage of PVn exceeds the allowable value.	Check the voltage of PVn, if the voltage exceeds 510V d.c., please decrease the PV string quantity.
PVn over-current	The current of PVn exceeds the allowable value.	1. Try to lower PV power. 2. Restart the hybrid inverter to see if the fault still exists. If it still exists, contact customer service.
PVn arc-fault	The arc of PVn abnormal.	Restart the hybrid inverter to see if the fault still exists. If it still exists, contact customer service.

Table6-3 Battery module fault description

Check item	Fault description	Solution
Battery over-voltage	Battery over-voltage	<ol style="list-style-type: none"> 1. Battery module discharge. 2. Check the fault, if the problem is not be solved yet, please call the service center.
Battery under-voltage	Battery under-voltage	<ol style="list-style-type: none"> 1. Charging the battery module. 2. Check the fault, if the problem is not be solved yet, please call the service center.
Excessive cell voltage difference	Excessive cell voltage difference	<ol style="list-style-type: none"> 1, Check if the battery SOC is low; 2. After the hybrid inverter is powered off and waiting for 30 minutes, then restart it. If the fault still exists, contact service.
Cell temperature abnormal	Cell temperature abnormal	<ol style="list-style-type: none"> 1. Check that the ambient temperature is within normal limits, if the ambient temperature is too high then try to reduce the surrounding temperature. If the ambient temperature is too low, raise the ambient temperature. 2. Make sure that the hybrid inverter is installed according to the manual and there is no block around the hybrid inverter. 3. After the hybrid inverter is powered off and waiting for 30 minutes, then restart it. If the fault still exists, contact service.
Output over-voltage	Output voltage abnormal	<ol style="list-style-type: none"> 1. Check if the PV component input voltage of hybrid inverter is too high; 2, Check the wiring for abnormalities; 2. Check if the problem is solved after power off; 3. Check the fault after restart the hybrid inverter, if the problem is not be solved yet, please call the service center.

Check item	Fault description	Solution
Battery over-current	Battery over-current	<ol style="list-style-type: none"> 1, Disconnect battery module output load, check if the problem is be solved; 2, Check if battery module voltage is normal; 2. 3. Check the fault after restart the hybrid inverter, if the problem is not be solved yet, please call the service center.
Battery insulation impedance protection	Battery insulation impedance abnormal	<ol style="list-style-type: none"> 1. If fault occurs when device power on in the morning, it may be caused by the wet weather. 2. Test impedance of ground to device by multimeter, if the impedance is not close to 0, there is a problem with the device wiring and ground wiring. 3. Test impedance of ground to BAT+/BAT- by multimeter. If the impedance is less than insulation impedance protection value, check if each port wiring is correct. 4. Install the device according to manual. 5. Check the fault, if the problem is not resolved, call for service.
Fan abnormal	Fan abnormal	<ol style="list-style-type: none"> 1. Check whether the fan is blocked. 2. Restart the hybrid inverter to see if the fault still exists. If it still exists, contact customer service.
Over-temperature	Equipment temperature too high	<ol style="list-style-type: none"> 1. Check whether the environment temperature is too high, try to lower the ambient temperature. 2. Make sure that the battery pack is installed in strict accordance with the manual, remove obstructions around the equipment, make sure that there is no direct sunlight, and that there are no obstructions, hot objects, or dangerous gases in the vicinity. 3. After the hybrid inverter is powered off and

Check item	Fault description	Solution
		waiting for 30 minutes, then restart it. If the fault still exists, contact service.
Output over-current	Output overload	1, check whether the load is too large, disconnect the load and restart to see whether it is normal; 2, check whether the battery voltage is normal; 3, set the battery power low, and then restart to see if it is normal;
SOC is too low	SOC is too low	1. The battery is almost empty, please charge the battery as soon as possible. 2. Charging the battery module.
Internal abnormal	Host internal abnormal	1. Check if the inner battery module is abnormal according to related information. 2. Restart the hybrid inverter, if the problem is not resolved, call for service, please call for service.
Address conflict	Device address repeat	1. Check if the address is repeated. 2. Set the address according to S/N. 3. If the problem is not resolved, call for service.
Communication wire abnormal	communication fault	1. Check if the wiring is correct. 2. If the problem is not resolved, call for service.

CAUTION

If the hybrid inverter has any alarm information mentioned in Table6-2. Please shut down the hybrid inverter (refer to 5. 2 Shutdown), 5 minutes later, restart the hybrid inverter (refer to 5. 1 Startup). If the alarm status is not removed, please contact our local dealer or service center. Before contacting us, please prepare the following information.

1. Hybrid inverter S/N.
2. Distributor/ dealer of the hybrid inverter (if has).
3. The date of grid-tied power generation.

4. Problem description.
 5. Your detail contact information.
-

7 Package, Transportation and Storage

This chapter introduces the package, transportation and storage of device.

7.1 Package

The device is packaged by carton. When packaging, pay attention to the placing direction requirements. On the side of the carton, there has warning icons, including keep dry, handle with care, up, stacking layer limit, etc. On the other side of the carton, it prints the device model, etc. On the front side of the carton, there is the logo of ATG company and device name.

7.2 Transportation

During transporting, pay attention to the warnings on the carton.

DO NOT make the device impact severely. To avoid damaging the device, place the device strictly according to the placement direction.

DO NOT carry the device with the objects that is inflammable, explosive, or corrosive.

DO NOT put the device in the open-air while midway transshipment. Leaching or mechanical damage by rain, snow or liquid objects is prohibited.

7.3 Storage

During storage, place the device strictly according to the direction that showed on the carton. Keep at least 20cm from the bottom of the carton to floor and keep at least 50cm from the carton to wall, heat source, cold source, windows or air inlet. The poisonous gas, inflammable or explosive or corrosive chemical objects are prohibited. Besides, strong mechanical shaking, impact or strong magnetic field is also prohibited. The storage temperature of hybrid inverter is -40°C - 70°C .

During battery module storage, please follow the four points below:

1. Wrap the positive and negative connector with insulating material to ensure that no metal parts are exposed to outside to avoid short circuit.
2. Battery module storage temperature requirement: short-term (with one month) storage in a clean and ventilated room at $-20^{\circ}\text{C}\sim 45^{\circ}\text{C}$, long-term (within one year) in a clean and ventilated room at $0^{\circ}\text{C}\sim 35^{\circ}\text{C}$ and the relative humidity of environment is $55\pm 20\%$.
3. During battery module storage, (SOC capacity state) should be kept above 30%. In order to prevent over discharge during long-term storage (more than three months), it should be charged regularly to ensure SOC is 30%~50%. It is recommended that the storage time after receiving the goods should not exceed half a year.
4. A battery module that has been shelved for a long time needs to be charged and discharged regularly, It is recommended to perform a standard charge and discharge cycle every 3 months in the initial stage.

After storing or transporting the device beyond the work temperature, keep the device aside and make its temperature return to normal range for more than 4h before installation.

A Technical Specifications

A.1 Technical Specifications of Hybrid Inverter

Item \ Model	ATG-ST-H01 -7.6kW	ATG-ST-H01 -9.6kW	ATG-ST-H01 -10kW	ATG-ST-H01 -11.4kW	ATG-ST-H01 -12kW
DC input(PV)					
Recommended Max.PV Input power (kWp)	18				
Max. PV input voltage (V d.c.)	500				
No. of MPPTs	4				
No. of PV strings per MPPT	1/1/1/1				
Max. PV input current (A d.c.)	15/15/15/15				
Max. PV short-circuit current (A d.c.)	18.75/18.75/18.75/18.75				
MPPT voltage range (V d.c.)	100~500				
Startup voltage (V d.c.)	125				
DC(PV) switch	Yes				
DC input(Battery)					
Battery voltage range (V d.c.)	360~500				
Max. charge/discharge current (A d.c.)	28				
AC input and output(On-grid)					

Item \ Model	ATG-ST-H01 -7.6kW	ATG-ST-H01 -9.6kW	ATG-ST-H01 -10kW	ATG-ST-H01 -11.4kW	ATG-ST-H01 -12kW
Rated AC output power (kW)	7.6	9.6	10	11.4	12
Rated grid voltage (V a.c.)	240				
Grid voltage range (V a.c.)	211.2~264				
Max. continuous input current (A a.c.)	31.7	40	41.7	47.5	50
Max. continuous output current (A a.c.)	31.7	40	41.7	47.5	50
Rated grid frequency (Hz)	60				
Grid frequency range (Hz)	58.5~61.2				
Power factor (rated power)	>0.99				
Power factor range	0.8 Leading ~ 0.8 Lagging				
THDi	<3% (rated power)				
AC input(GEN)					
Max. AC output power(kW)	7.6	9.6	10	11.4	12
Max. AC current (A a.c.)	31.7	40	41.7	47.5	50
AC voltage range (V a.c.)	120/240, 2W/N/PE, Split phase				
AC output(Back-up)					
Rated AC output voltage (V a.c.)	120/240, 2W/N/PE, Split phase				
Rated output frequency (Hz)	60				
Rated AC output power (kW)	7.6	9.6	10	11.4	12
Rated output current (A a.c.)	31.7	40	41.7	47.5	50
Peak AC output power(kW)	15.2 (10s)	19.2 (10s)	20 (10s)	22.8 (10s)	24 (10s)
Peak output current (A a.c.)	63.4(10s)	80(10s)	83.4(10s)	95(10s)	100(10s)

Item \ Model	ATG-ST-H01 -7.6kW	ATG-ST-H01 -9.6kW	ATG-ST-H01 -10kW	ATG-ST-H01 -11.4kW	ATG-ST-H01 -12kW
Switch time	<20ns(Single Unit), <200ms(With BTS200-US)				
Support the unbalance load	Yes				
Efficiency					
Max. efficiency(PV to Grid)	97.5%				
CEC. efficiency(PV to Grid)	96.8%				
Protection & Safety					
DC reverse connection protection	Yes				
Anti-island	Yes				
Zero-export	Yes				
AC short-circuit protection	Yes				
Leakage current protection (RCD)	Yes				
PV fault detect	Yes				
Input DC impedance monitor	Yes				
Surge protection	TYPE II				
Integrated arc fault circuit interrupter(AFCI)	Yes				
PV Rapid Shutdown	Yes (integrated Tigo transmitter, compatibility with TS4-A-F/2F)				
General					
Weight (kg/lb)	32/70.55				
Size (W×H×D) (mm/in)	800×450×200/ 31.50×17.72×7.87 (including side plates)				
Installation method	Wall-mounted				
Insulation	No transformer				
Ingress production	NEMA Type 3R				

Item	Model	ATG-ST-H01	ATG-ST-H01	ATG-ST-H01	ATG-ST-H01	ATG-ST-H01
		-7.6kW	-9.6kW	-10kW	-11.4kW	-12kW
Pollution grade	C3					
Self-consumption at night	<10W					
Operating temperature range (°C/ °F)	-20~50/ -4~122					
Relative humidity	0~100% (Non-condensing)					
Cooling type	Natural cooling					
Max. operating altitude (m/ft)	3000/9842 (Derating above 2000m/6561ft)					
Noise emission (dB)	<40@ 1m					
Display	LED&APP					
Communication interface	Portal-Wi-Fi (standard)/4G (optional), Meter-RS485					
AC terminal	E10-12: Grid (max.10mm ²) Backup (max.10mm ²)					
PV DC terminal	CE040010 (max.6mm ²)					
BAT terminal	ES057 (max.10mm ²) or the wire equipped by the device.					
Certification	UL1741, CFR 47, FCC Part 15, UL1741SB, CSA C22.2, IEEE1547, IEEE1547.1, UL1699B, UL1998, CEC, PVRSS, IEEE 2030.5					

- Specifications are subject to change without prior notice.
- The external communication circuit of rechargeable Lithium-ion battery module needs to be considered reinforced insulation with power circuit, the reinforced insulation of clearance and creepage should be considered with system voltage and impulse in the system.

A.2 Technical Specifications of Battery Module

Item	Model
General	
Battery type	LiFePO4

Item \ Model	Model
	ATG-B-H01-5kWh
Energy capacity (kWh)	5
Usable capacity (kWh) ¹	4.9
Scalability	4
Scalable capacity range (kWh)	5~20
Rated pwer(kW)	2.5
Input voltage range (V d.c.)	360~500
Max. charge current (A d.c.)	6.94
Max. discharge current (A d.c.)	6.94
Peak discharge current (A d.c.)	8.3A, 10s
Size (W×H×D) (mm/in)	800*380*200/31.50*14.96*7.87(including side plates)
Weight (kg/lb)	49/108.02
Operating temperature range (°C/ °F)	-20~50/-4~122
Relative humidity	0~100%(Non-condensing)
Max. operating altitude (m/ft)	3000/9842 (Derating above 2000/6561)
Cooling type	Natural cooling
User interface	LED
Communication interface	CAN, RS485
Topology	Isolated
Installation method	Floor-mounted and wall-mounted
Enclosure type	NEMA type 3R
BAT terminal	ES057 (max.10mm ϕ) or the wire equipped by the device.
Noise emission (dB)	<40dB@1m optimal

Item	Model ATG-B-H01-5kWh
Certification	UL1973, UL60730, UN38.3

- Specifications are subject to change without prior notice.
- *1 Test conditions: 25 °C, 100 % depth of discharge (DOD), 0.2C charge & discharge
- *2 Charge 0~50 °C/32 °F~122 °F (0 °C to 50 °C), Discharge -4 °F~122 °F (-20 °C to 50 °C)

A.3 Technical Specifications of system

A.3.1 ATG-ST-H01-7.6kW~12kW-5kWh

Item	Model	ATG-ST-H01 -7.6kW-5kWh	ATG-ST-H01 -9.6kW-5kWh	ATG-ST-H01 -10kW-5kWh	ATG-ST-H01 -11.4kW -5kWh	ATG-ST-H01 -12kW-5kWh
System components						
Inverter model		ATG-ST-H01-7.6kW	ATG-ST-H01-9.6kW	ATG-ST-H01-10kW	ATG-ST-H01-11.4kW	ATG-ST-H01-12kW
Number of inverter		1				
Battery system model		ATG-B-H01-5kWh				
Number of battery module		1				
Accessories		200A CT(optional), METER with 100A CT(optional), Outdoor rapid shutdown button(optional)				
General						
System capacity (kWh)		5				
Rated system power(kW)		7.6	9.6	10	11.4	12
Max. discharge power(no sun) (kW)		2.4	2.4	2.4	2.4	2.4
Peak off-grid power(full sun) (kW) ¹		15.2(10s)	19.2(10s)	20(10s)	20.8(10s)	20.8(10s)
Peak off-grid power(no sun) (kW) ²		2.8(10s)	2.8(10s)	2.8(10s)	2.8(10s)	2.8(10s)
Installation dimension(W*H*D) (mm/in)		800*905*240/31.5*35.6*9.4				

Item	Model	ATG-ST-H01 -7.6kW-5kWh	ATG-ST-H01 -9.6kW-5kWh	ATG-ST-H01 -10kW-5kWh	ATG-ST-H01 -11.4kW -5kWh	ATG-ST-H01 -12kW-5kWh
Noise emission(dB)	<40@1m optimal					
Cooling type	Natural cooling					
Altitude(m/ft)	3000/9842 (derating above 2000/6561)					
Operating temperature(°C/ °F)	-20~50/-4~122					
Operating humidity	0~100%(Non-condensing)					
Display	LED&APP					
Installation method	Floor and wall-mounted					
Certification	UL9540, UL9540A					

*Specifications are subject to change without prior notice.

*1 Values provided according to recommended Max. PV input power.

*2 System work in Off-grid mode and values provided for 25 °C (77 °F)

A.3.2 ATG-ST-H01-7.6kW~12kW-10kWh

Item	Model	ATG-ST-H01 -7.6kW -10kWh	ATG-ST-H01 -9.6kW -10kWh	ATG-ST-H01 -10kW -10kWh	ATG-ST-H01 -11.4kW -10kWh	ATG-ST-H01 -12kW -10kWh
System components						
Inverter model	ATG-ST- H01-7.6kW	ATG-ST- H01-9.6kW	ATG-ST- H01-10kW	ATG-ST- H01-11.4kW	ATG-ST- H01-12kW	
Number of inverter	1					
Battery system model	ATG-B-H01-5kWh					
Number of battery module	2					
Accessories	200A CT(optional), METER with 100A CT(optional), Outdoor rapid shutdown button(optional)					
General						

Item	Model	ATG-ST-H01	ATG-ST-H01	ATG-ST-H01	ATG-ST-H01	ATG-ST-H01
		-7.6kW -10kWh	-9.6kW -10kWh	-10kW -10kWh	-11.4kW -10kWh	-12kW -10kWh
System capacity (kWh)	10					
Rated system power(kW)	7.6	9.6	10	11.4	12	
Max. discharge power(no sun) (kW)	4.8	4.8	4.8	4.8	4.8	
Peak off-grid power(full sun) (kW) ¹	15.2(10s)	19.2(10s)	20 (10s)	22.8(10s)	23.7(10s)	
Peak off-grid power(no sun) (kW) ²	5.7(10s)	5.7(10s)	5.7(10s)	5.7(10s)	5.7(10s)	
Installation dimension(W*H*D) (mm/in)	800*1285*240/31.5*50.6*9.4					
Noise emission(dB)	<40@1m optimal					
Cooling type	Natural cooling					
Altitude(m/ft)	3000/9842 (derating above 2000/6561)					
Operating temperature(°C/ °F)	-20~50/-4~122					
Operating humidity	0~100%(Non-condensing)					
Display	LED&APP					
Installation method	Floor and wall-mounted					
Certification	UL9540, UL9540A					

*Specifications are subject to change without prior notice.

*1 Values provided according to recommended Max. PV input power.

*2 System work in Off-grid mode and values provided for 25 °C (77 °F)

ATG-ST-H01-7.6kW~12kW-15kWh

Item	Model	ATG-ST-H01	ATG-ST-H01	ATG-ST-H01	ATG-ST-H01	ATG-ST-H01
		-7.6kW -15kWh	-9.6kW -15kWh	-10kW -15kWh	-11.4kW -15kWh	-12kW -15kWh
System components						
Inverter model	ATG-ST-H01	ATG-ST-H01	ATG-ST-H01	ATG-ST-H01	ATG-ST-H01	ATG-ST-H01
	-7.6kW	-9.6kW	-10kW	-11.4kW	-12kW	

Item	Model	ATG-ST-H01	ATG-ST-H01	ATG-ST-H01	ATG-ST-H01	ATG-ST-H01
		-7.6kW -15kWh	-9.6kW -15kWh	-10kW -15kWh	-11.4kW -15kWh	-12kW -15kWh
Number of inverter	1					
Battery system model	ATG-ST-H01-5kWh					
Number of battery module	3					
Accessories	200A CT(optional), METER with 100A CT(optional), Outdoor rapid shutdown button(optional)					
General						
System capacity (kWh)	15					
Rated system power(kW)	7.6	9.6	10	11.4	12	
Max. discharge power(no sun) (kW)	7.2	7.2	7.2	7.2	7.2	
Peak off-grid power(full sun) (kW) ¹	15.2(10s)	19.2(10s)	20(10s)	22.8(10s)	24(10s)	
Peak off-grid power(no sun) (kW) ²	8.5(10s)	8.5(10s)	8.5(10s)	8.5(10s)	8.5(10s)	
Installation dimension(W*H*D) (mm/in)	800*1665*240/31.5*65.6*9.4					
Noise emission(dB)	<40@1m optimal					
Cooling type	Natural cooling					
Altitude(m/ft)	3000/9842 (derating above 2000/6561)					
Operating temperature(°C/ °F)	-20~50/-4~122					
Operating humidity	0~100%(Non-condensing)					
Display	LED&APP					
Installation method	Floor and wall-mounted					
Certification	UL9540, UL9540A					

*Specifications are subject to change without prior notice.

*1 Values provided according to recommended Max. PV input power.

*2 System work in Off-grid mode and values provided for 25 °C (77 °F)

A.3.3 ATG-ST-H01-7.6kW~12kW-20kWh

Item	Model	ATG-ST-H01 -7.6kW -20kWh	ATG-ST-H01 -9.6kW -20kWh	ATG-ST-H01 -10kW -20kWh	ATG-ST-H01 -11.4kW -20kWh	ATG-ST-H01 -12kW -20kWh
System components						
Inverter model		ATG-ST-H01 -7.6kW	ATG-ST-H01 -9.6kW	ATG-ST-H01 -10kW	ATG-ST-H01 -11.4kW	ATG-ST-H01 -12kW
Number of inverter		1				
Battery system model		ATG-ST-H01-5kWh				
Number of battery module		4				
Accessories		200A CT(optional), METER with 100A CT(optional), Outdoor rapid shutdown button(optional)				
General						
System capacity (kWh)		20				
Rated system power(kW)		7.6	9.6	10	11.4	12
Max. discharge power(no sun) (kW)		7.6	9.6	9.6	9.6	9.6
Peak off-grid power(full sun) (kW) ¹		8.5(10s)	(10s)	20(10s)	22.8(10s)	24(10s)
Peak off-grid power(no sun) (kW) ²		8.5(10s)	8.5(10s)	8.5(10s)	8.5(10s)	8.5(10s)
Installation dimension(W*H*D) (mm/in)		800*1665*240/31.5*65.6*9.4				
Noise emission(dB)		<40@1m optimal				
Cooling type		Natural cooling				
Altitude(m/ft)		3000/9842 (derating above 2000/6561)				
Operating temperature(°C/ °F)		-20~50/-4~122				
Operating humidity		0~100%(Non-condensing)				
Display		LED&APP				

Item \ Model	ATG-ST-H01 -7.6kW -20kWh	ATG-ST-H01 -9.6kW -20kWh	ATG-ST-H01 -10kW -20kWh	ATG-ST-H01 -11.4kW -20kWh	ATG-ST-H01 -12kW -20kWh
Installation method	Floor and wall-mounted				
Certification	UL9540, UL9540A				

*Specifications are subject to change without prior notice.

*1 Values provided according to recommended Max. PV input power.

*2 System work in Off-grid mode and values provided for 25 °C (77 °F)

B System Diagram

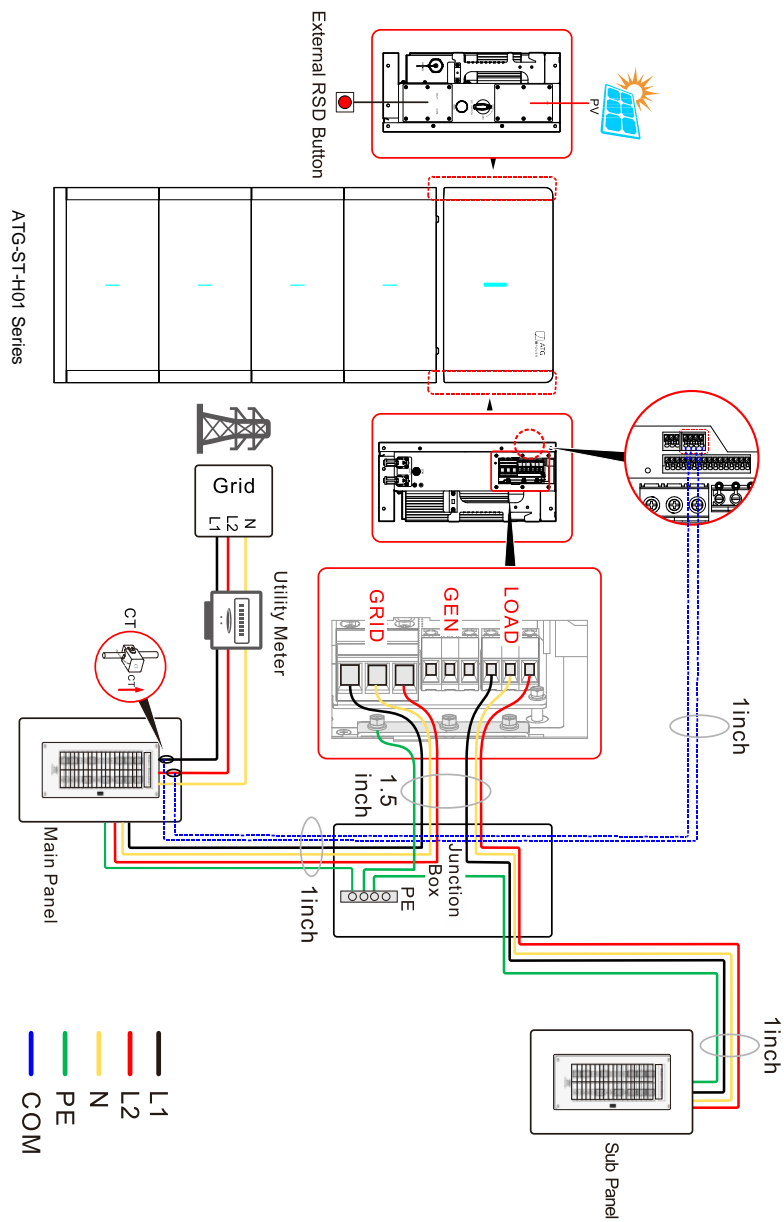

Figure B-1 System diagram 1

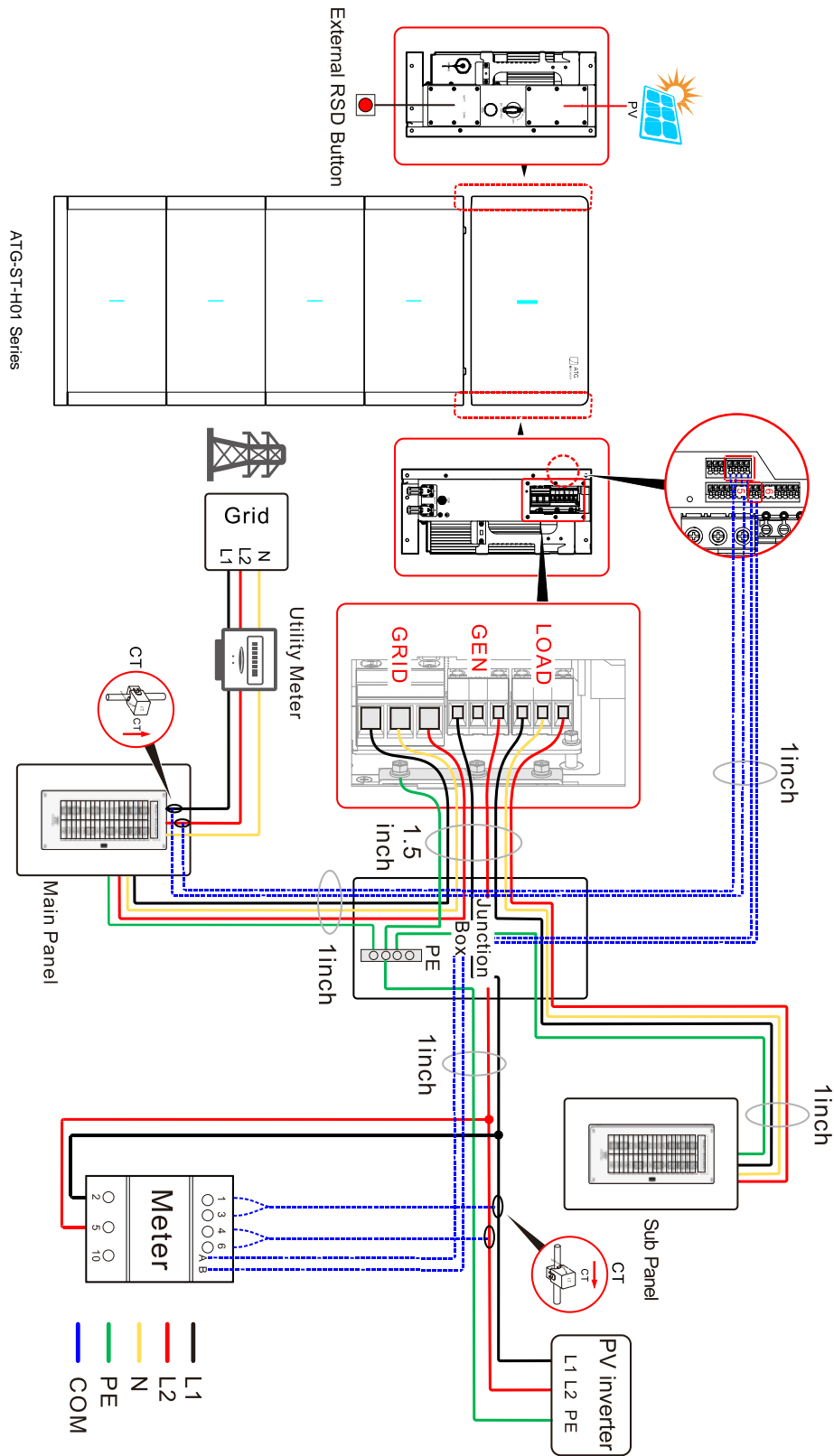

Figure B-2 System diagram 2

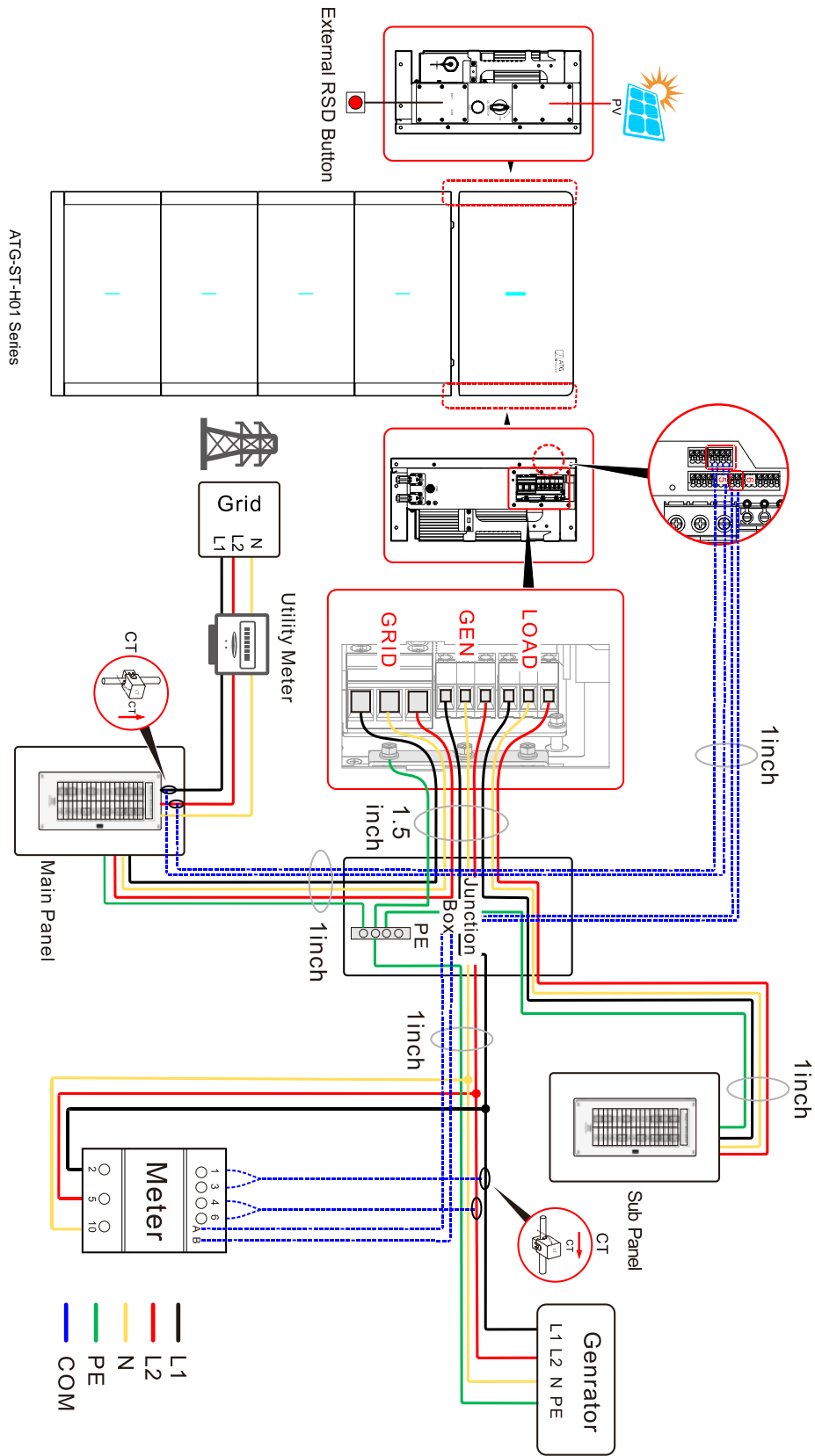

Figure B-3 System diagram 3

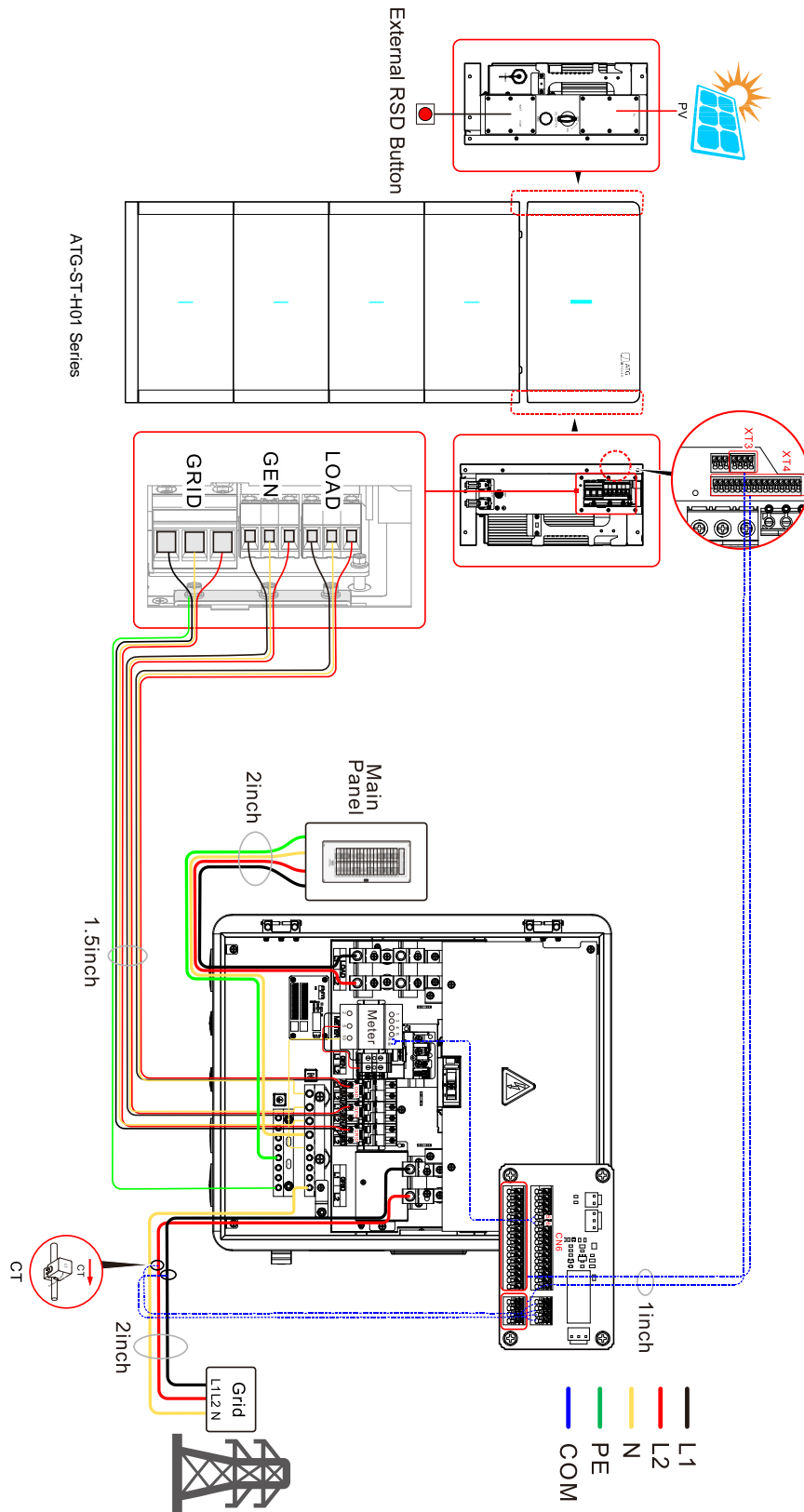

Figure B-4 System diagram 4

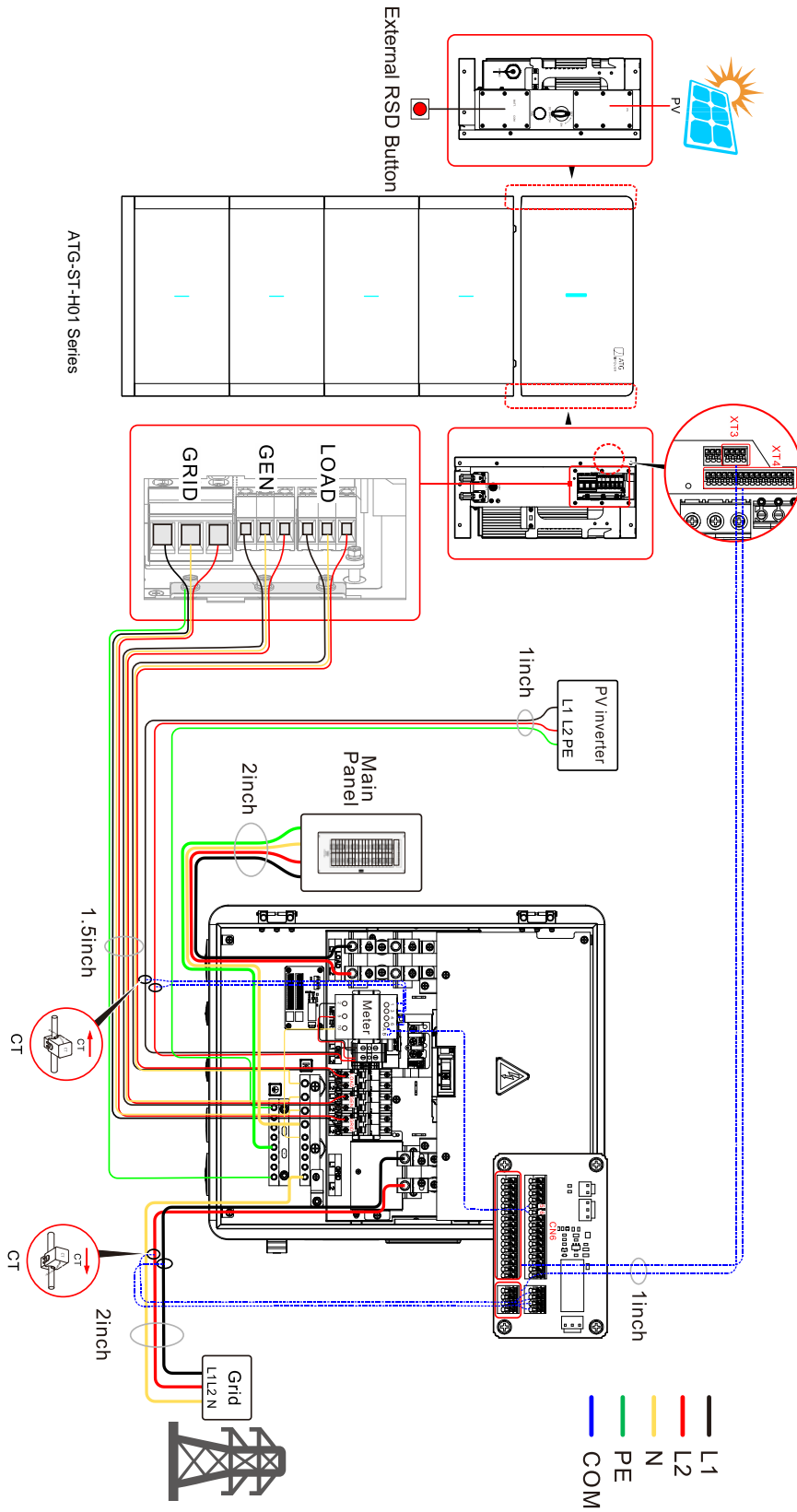

Figure B-5 System diagram 5

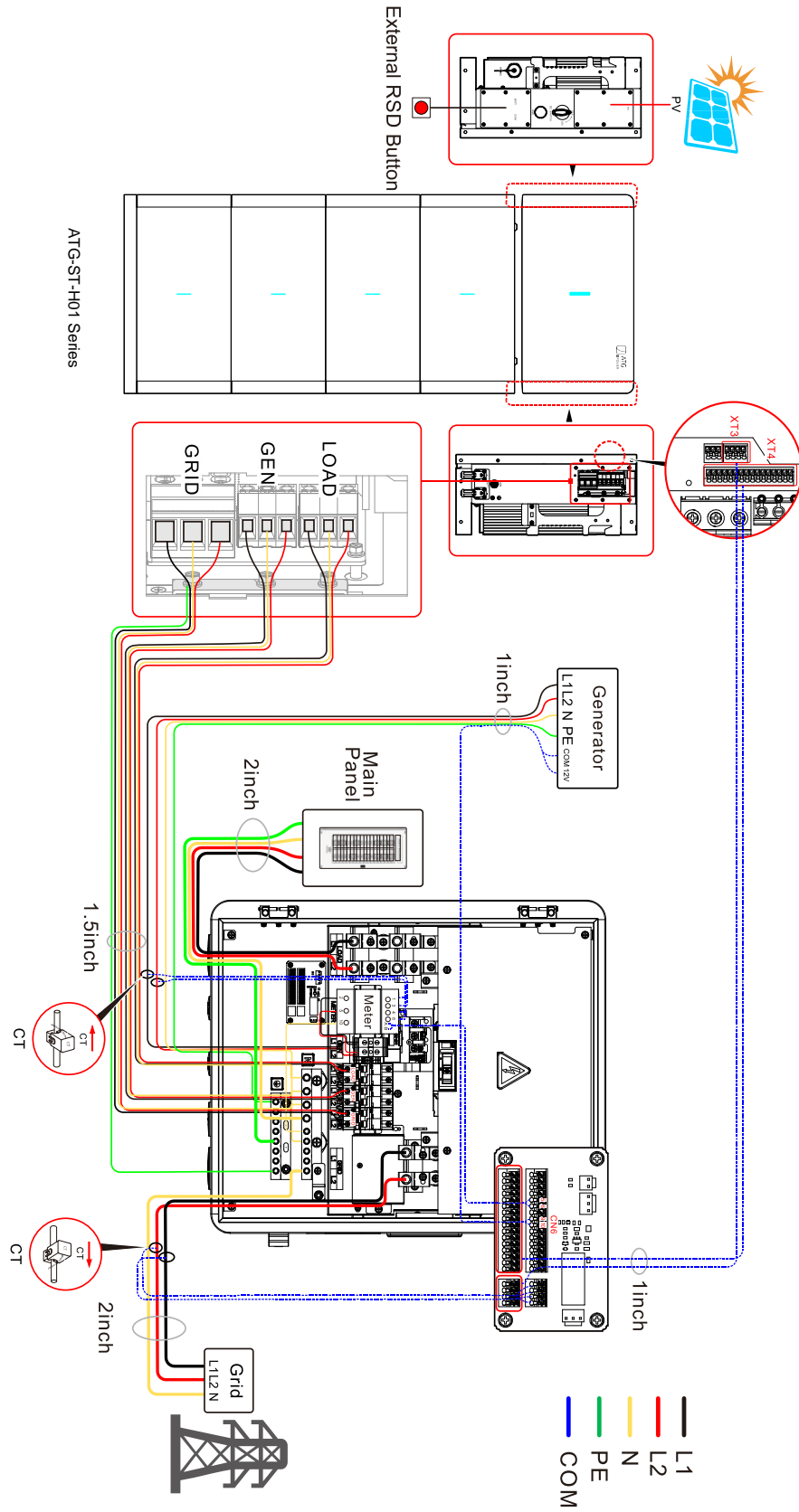

Figure B-6 System diagram 6

**NOTE**

- 200A CT is used for grid site metering, calculate all house load consumption.
- METER is used for metering the AC coupled inverter or generator current.
- 200A CT must be installed if the system requires zero-export function.
- In whole house backup system, 200A CT and Meter are installed in the distribution box.
- In partial house backup system, it's recommended to install a junction box or switch between hybrid inverter and panel.
- The PV inverter is connected to the hybrid inverter through fuse disconnect.
- If the hybrid inverter is not connected to PV array and the battery is discharged to protection, the system will wait until the grid is restored to resume operation, otherwise the system cannot be restarted during the day.
- Generator device requirements include
 1. 240/120Vac, Split phase with neutral
 2. Voltage range is -10% to +10%
 3. Frequency range is +/- 5%
 4. Generator start-up types requires two-wire start
 5. Total Harmonic Distortion < 25%