



## EV Charger

# INSTALLATION AND USER GUIDE



**ATG Electronics, Inc.**

10588 Monte Vista Ave, Montclair, CA 91763

+1-951-245-6222

[service@atgelectronics.com](mailto:service@atgelectronics.com)

<https://www.atgelectronics.com/>



1. Safety Information.....2-4

2. Specifications.....5-7

3. Check Box Contents.....8

4. Tools Needed.....9

5. Installation Overview.....10-15

Step 1: Download the OCPP Configuration Tool.....10

Step 2a-1-7: Hardwired Instructions for Electricians.....11-15

6. Charging your Vehicle.....16

7. EV Charger LED Lights.....17-18

8. Troubleshooting Tips.....19

9. FCC .....20

10. Maintenance and Repair.....21

11. Service.....21



**IMPORTANT SAFETY INSTRUCTIONS  
SAVE THESE INSTRUCTIONS**

**Instructions Pertaining To A Risk Of Fire Or Electric Shock!**

Improper connection of the equipment- grounding conductor may result in a risk of electric shock, leading to death or serious injury. ATG e-Power recommends that installation be performed by a licensed electrician or other qualified professional in accordance with the regional electrical code where it is being installed to ensure the ATG e-Power EV Charger is properly grounded. Do not modify the provided plug – if it will not fit the outlet, have a proper outlet installed by a licensed electrician or other qualified professional.

**Grounding Instructions For Plugged-in Installation:**

This product must be grounded. If it should malfunction or break down, grounding provides a path of least resistance for electric current to reduce the risk of electric shock. This product is equipped with a cord having an equipment grounding conductor and a grounding plug. The plug must be plugged into an appropriate outlet that is properly installed and grounded in accordance with all local codes and ordinances.

**WARNING** - Improper connection of the equipment-grounding conductor can result in a risk of electric shock. Check with a qualified electrician or serviceman if you are in doubt as to whether the product is properly grounded. Do not modify the plug provided with the product –if it will not fit the outlet, have a proper outlet installed by a qualified electrician.

**For Hardwired Installation:**

This product must be connected to a grounded, metal, permanent wiring system, or an equipment-grounding conductor must be run with the circuit conductors and connected to the equipment grounding terminal or lead on the product.

## **IMPORTANT SAFETY INSTRUCTIONS**

### **SAVE THESE INSTRUCTIONS**

#### **INSTRUCTIONS PERTAINING TO A RISK OF FIRE OR ELECTRIC SHOCK**

- Read all the instructions before using this product.
- This device should be supervised when used around children. Do not put fingers into the electric vehicle connector.
- The ATG e-Power EV Charger is intended for use with electric vehicles only. Specifically, it is intended only for charging vehicles not requiring ventilation during charging.
- Do not use the ATG e-Power EV Charger in any manner other than specified in this installation guide. Refer servicing to qualified service personnel.
- Do not attempt to disassemble or repair any of the components of the ATG e-Power EV Charger. There are no user serviceable parts inside.
- Do not use this product if the flexible power cord or EV cable is frayed, has broken insulation, or any other signs of damage.
- Do not use this product if the enclosure or the EV connector is broken, cracked, open, or shows any other indication of damage.
- Do not install the ATG e-Power EV Charger in environments with explosive gas or vapors; nor where temperatures are outside its operating range of -22°F to 122°F (-30°C to 50°C).
- Use 105°C wire, 6 AWG copper for setting 48A rating intended for field wiring connection.

- Improper moving or storage of the ATG e-Power EV Charger may result in damage to the product that could result in a risk of fire or electric shock during subsequent use.
- Handle charger and packaging with care and avoid dropping it. When moving or lifting the ATG e-Power EV Charger, always grasp the unit by the charging station enclosure. Never carry or lift the ATG e-Power EV Charger by either the power cable or charging cord.
- Store the ATG e-Power EV Charger indoors and in its original packaging until it is ready to be installed. Storage temperature should be between -22°F to 122°F (-30°C to 50°C).

### Electrical Characteristics

- › Safety Rated: 32A Max
- › Single phase input: nominal voltage 208-240 VAC~60 Hz
- › Power: 7.6 kW at 240 VAC

### Input Cable

- › Hardwired 2.6ft/0.8m cable

### Output Cable & Connector

- › 18 ft/5.5 m cable
- › SAE J1772 standard compliant



### App

- › Precision measurement of power, energy, voltage & current
- › Automated notifications: time-of-use in effect, start of charge, end of charge, unit offline, unit back online, car not plugged in by a set time

### Smart Grid Connectivity

- › Built-in WIFI (802.11 b/g/n/2.4GHz) / Bluetooth Connectivity

### Firmware

- › Over-the-air (OTA) upgradeable firmware

### Emissions Reduction

- › Available via optional software upgrade

### Enclosure

- › Dynamic LED lights show charging status: standby, Deviceconnectivity, charging in progress, fault indicator, network connectivity
- › NEMA Enclosure Type4: Weatherproof, dusttight
- › IK10: Resistant polycarbonate case
- › Quick-release wall mounting bracket included
- › Operating Temperature: 22°F to 122°F ( -30°C to 50°C )

### Dimensions

- › Main enclosure: 12.3in x 10.2in x 4.1in (313mm x 260mm x 105mm)

### Codes & Standards

- › NEC625 compliant, UL2594 compliant, OCP1.6J, FCC Part 15 Class B, Energy Star

### Safety

- › ETL Listed

### RFID

- › Support

### Warranty

- › 5 years limited product warranty

### Electrical Characteristics

- › Safety Rated: 40A Max
- › Single phase input: nominal voltage 208-240 VAC~60 Hz
- › Power: 9.6 kW at 240 VAC

### Input Cable

- › Hardwired 2.6ft/0.8m cable

### Output Cable & Connector

- › 18 ft/5.5 m cable
- › SAE J1772 standard compliant



### App

- › Precision measurement of power, energy, voltage & current
- › Automated notifications: time-of-use in effect, start of charge, end of charge, unit offline, unit back online, car not plugged in by a set time

### Smart Grid Connectivity

- › Built-in WIFI (802.11 b/g/n/2.4GHz) / Bluetooth Connectivity

### Firmware

- › Over-the-air (OTA) upgradeable firmware

### Emissions Reduction

- › Available via optional software upgrade

### Enclosure

- › Dynamic LED lights show charging status: standby, Deviceconnectivity, charging in progress, fault indicator, network connectivity
- › NEMA Enclosure Type4: Weatherproof, dusttight
- › IK10: Resistant polycarbonate case
- › Quick-release wall mounting bracket included
- › Operating Temperature: 22°F to 122°F ( -30°C to 50°C )

### Dimensions

- › Main enclosure: 12.3in x 10.2in x 4.1in (313mm x 260mm x 105mm)

### Codes & Standards

- › NEC625 compliant, UL2594 compliant, OCP1.6J, FCC Part 15 Class B, Energy Star

### Safety

- › ETL Listed

### RFID

- › Support

### Warranty

- › 5 years limited product warranty

### Electrical Characteristics

- > Safety Rated: 48A Max
- > Single phase input: nominal voltage 208-240 VAC~60 Hz
- > Power: 11.5 kW at 240 VAC

### Input Cable

- > Hardwired 2.6ft/0.8m cable

### Output Cable & Connector

- > 18 ft/5.5 m cable
- > SAE J1772 standard compliant

### App

- > Precision measurement of power, energy, voltage & current
- > Automated notifications: time-of-use in effect, start of charge, end of charge, unit offline, unit back online, car not plugged in by a set time

### Smart Grid Connectivity

- > Built-in WIFI (802.11 b/g/n/2.4GHz) / Bluetooth Connectivity

### Firmware

- > Over-the-air (OTA) upgradeable firmware

### Emissions Reduction

- > Available via optional software upgrade

### Enclosure

- > Dynamic LED lights show charging status: standby, Device connectivity, charging in progress, fault indicator, network connectivity
- > NEMA Enclosure Type4: Weatherproof, dusttight
- > IK10: Resistant polycarbonate case
- > Quick-release wall mounting bracket included
- > Operating Temperature: 22°F to 122°F ( -30°C to 50°C )

### Dimensions

- > Main enclosure: 12.3in x 10.2in x 4.1in (313mm x 260mm x 105mm)

### Codes & Standards

- > NEC625 compliant, UL2594 compliant, OCPP 1.6J, FCC Part 15 Class B, Energy Star

### Safety

- > ETL Listed

### RFID

- > Support

### Warranty

- > 5 years limited product warranty



Your new ATG e-Power EV Charger contains the following items. **If any of these items are missing or if you believe they've been damaged, call support immediately.**

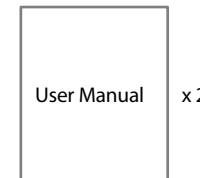
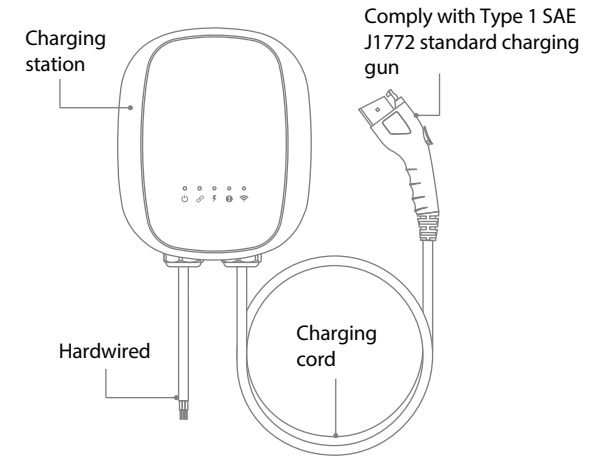

- EV charger installation and usage instruction
- APP/ OCPP Configuration Tool instruction

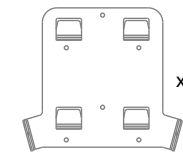

Mounting bracket

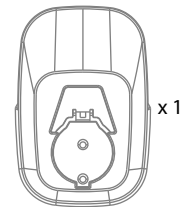

Gun cradle



Eight drywall anchors

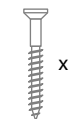

Eight 7/32 inch #12 Phillips screws



Two M4X8 hand-screws

Here are the tools you will need to install the EV Charger.

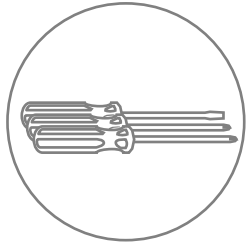

Phillips, flathead and torx screwdrivers

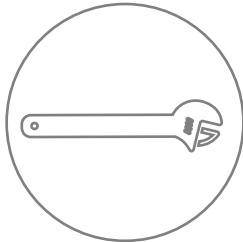

Adjustable Wrench



IOS or Android phone or tablet

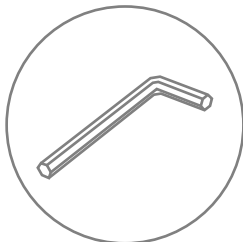

Allen Wrench

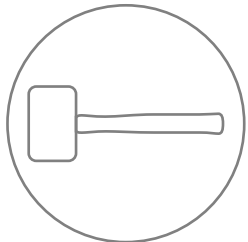

Rubber Mallet

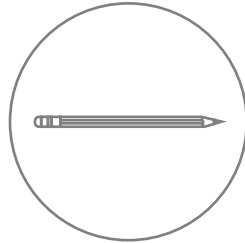

Pencil



Drill with a 5/16" drill bit

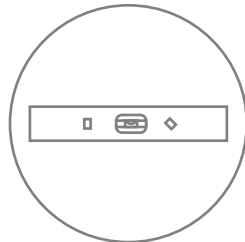

Bubble Level

- Use your phone or tablet to scan below QR code.
- Find "OCPP Config Tool" App, click "Download" to download the Tool to your phone or tablet and begin the configure process.



A licensed electrician or other qualified professional can follow these **instructions to hardwire the EV Charger to a breaker. If you plan to power your EV Charger with a NEMA 14-50R/6-50R receptacle outlet, skip to Step 9b.** First, turn off the dedicated dual-pole breaker that will power the EV Charger.

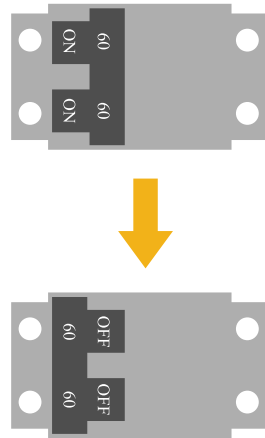

From the back of the EV Charger, use the Allen wrench to remove the 8 screws to detach the front cover. Use an adjustable wrench to remove water-proof joints.

**CAUTION:** There's a cable connecting the cover to the circuit board in the Charger. To remove the cable, gently grab the cable bundle and pull it away from the circuit board.

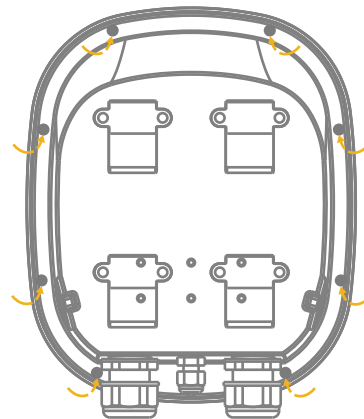

Unscrew the screws for terminals L1, L2, and GND, to remove the NEMA cable wires.

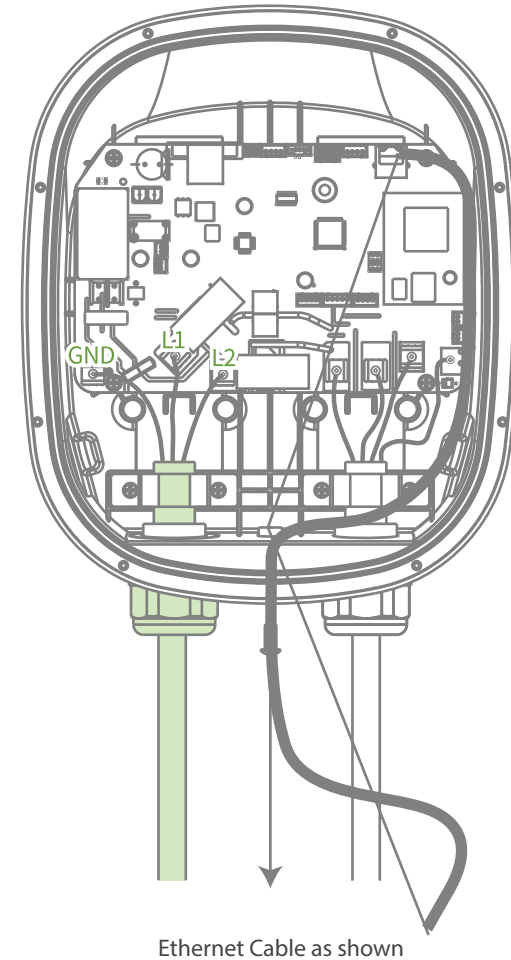

Unscrew the screws to remove the clamp securing NEMA cable. Then, remove the NEMA cable from the assembly. Finally, unscrew the nut holding the cable gland in place and remove it from the assembly.

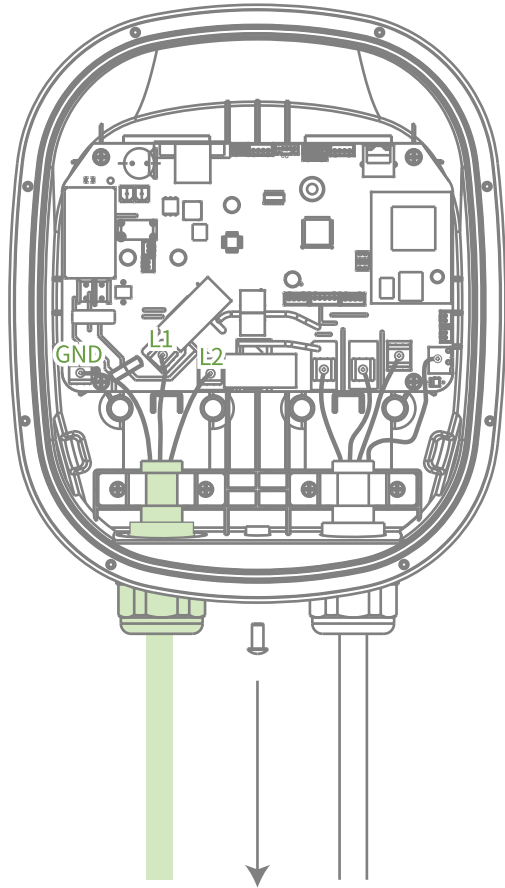

Pull out the plug rod of the middle waterproof connector, insert the Ethernet cable, and tighten the nut.

Using 1-1/4" conduit and proper fittings for the connections, use copper conductor only, 105°C, 6 AWG for setting 48A rating from both phases of the breaker along with a ground/earth lead into the EV Charger assembly. Put the phase 1 lead into terminal L1, the phase 2 lead into terminal L2, and the ground into terminal GND and secure them with the screws, applying a tightening torque of 1.2 Nm.

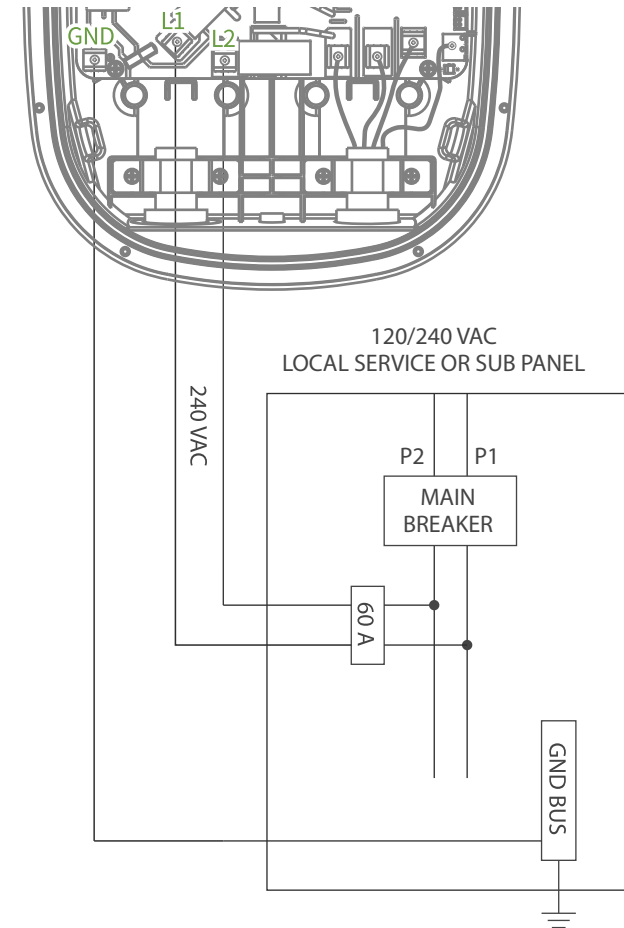



**Gently reattach the cable to the cover and the circuit board. Then, from the back of the EV Charger, use the Allen wrench to replace the 8 screws to reattach the front cover.**

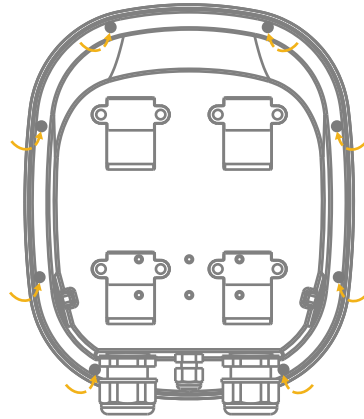

Turn on the breaker and ensure that the power light on the front of the EV Charger is illuminated.

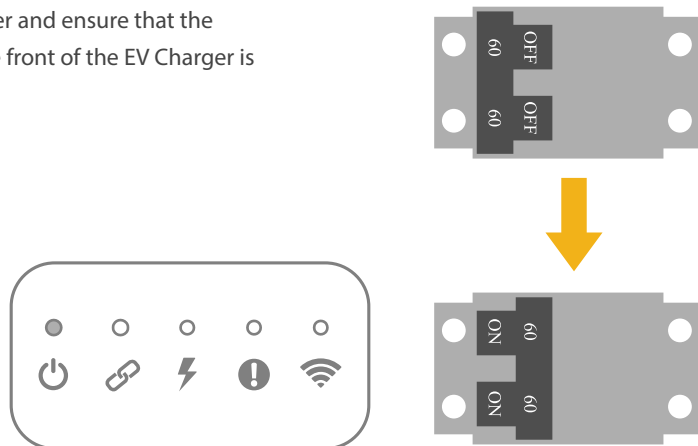

Factory setting: Base on the maximum EV charger capacity that the car system will accept. You can raise or lower this rate through the ATG e-Power APP or OCPP Configuration Tool.

The default factory setting of charging mode is Plug and Play. If it is a smart home charger, switch to APP mode, please. refer to ATG e-Power APP instruction. If it is a commercial charger (OCPP version), switch the mode through the ATG e-Power OCPP Configuration Tool in the phone or tablet.

To start charging the vehicle, open the port door and plug the EV Charger gun into the port. You will see the charge light on the EV Charger switch to solid green when it is connected to the vehicle. It will begin to flash green, as the vehicle charges. Additionally, most EVs have indicator lights on the dashboard to let you know that you are charging. Do not attempt to drive your vehicle while the charge cable is connected to your vehicle.

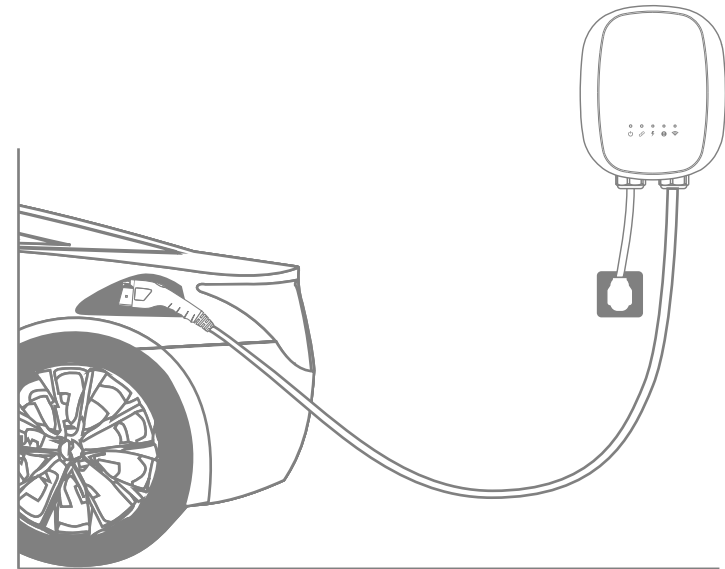

Power	
Off	Charger does not have power
Solid Blue	Charger has power
Connect	
Off	Faulty charging signal from the car
Flash Green	Charge Mode
Solid Green	Pre-Charge Mode
Charge	
Off	Idle Mode
Flash Green	Charging Mode
Solid Green	Pre-Charge Mode
W i-Fi/4G	
Off	Not connected to WIFI/4G network
Solid Green	Connected to the WIFI/4G network

**CAUTION:** Do not touch and use this product when in case of failure. It is required to disconnect the power supply or have it handled by professionals.

Fault	
Red light flashing every 3 seconds (once)	Input voltage is too high If plugged in, check that the NEMA14-50P or NEMA6 -50P is plugged in securely. Check the supply breaker in your breaker panel for damage and replace if necessary. If issue persists, contact Support.
Red light flashing every 3 seconds (twice)	Input voltage is too low If plugged in, check that the NEMA14-50P or NEMA6 -50P is plugged in securely. Check the supply breaker in your breaker panel for damage and replace if necessary. If issue persists, contact Support.
Red light flashing every 3 seconds (three times)	Output over current Unplug from car. Disconnect charger from power. Confirm there is no visible damage or foreign material in the EV gun. Return power to charger. If issue persists, contact Support
Red light flashing every 3 seconds (four times)	Charger has exceeded nominal temperature. Ensure the charger is installed where ambient temperatures will not exceed 122°F (50°C). If issue persists, contact Support.
Red light flashing every 3 seconds (five times)	Current leakage. Unplug from car. Disconnect charger from power. Confirm there is no visible damage or foreign material in the EV gun. Return power to charger. If issue persists, contact Support.
Red light flashing every 3 seconds (six times)	Charger is not grounded Ensure that the EV Charger is properly wired and grounded. Check the line and neutral connections, as they may be reversed in the adapter or outlet. Unplug and reboot EV charger. If issue persists, contact Support.
Red light flashing every 3 seconds (seven times)	CP line not properly connected.
Red light flashing every 3 seconds (eight times)	Relay fused in position Disconnect from power immediately. Contact Support.

### The ATG e-Power APP is not finding my EV Charger after I've installed it.

- Ensure the Charger has power:
  - Check for a green power light.
  - Check the EV Charger is wired properly.
  - Check that the breaker powering the EV Charger is turned on.
- Ensure your phone can connect to the EV Charger.
  - Check your phone's Bluetooth is on.
- Try power cycling the breaker to which the EV Charger is connected.
- Try restarting the ATG e-Power APP.
- Try rebooting your phone.

### My vehicle is not responding or charging.

- Ensure that the latch on the EV charging cable handle is locked into place. If the handle is not latched securely, the vehicle will not charge. If the latch is pressed down during charging, charging automatically stops.
- Ensure that the vehicle is not set up to begin charging at a specific time of day.



### The ATG e-Power EV Charger contains

This device complies with Part 15 of the FCC Rules / Industry Canada license-exempt RSS standard (s). Operation is subject to the following two conditions: (1) this device may not cause harmful interference, and (2) this device must accept any interference received, including interference that may cause undesired operation.

This equipment has been tested and found to comply with the limits for a Class B digital device, pursuant to part 15 of the FCC Rules. These limits are designed to provide reasonable protection against harmful interference in a residential installation. This equipment generates uses and can radiate radio frequency energy and, if not installed and used in accordance with the instructions, may cause harmful interference to radio communications. However, there is no guarantee that interference will not occur in a particular installation. If this equipment does cause harmful interference to radio or television reception, which can be determined by turning the equipment off and on, the user is encouraged to try to correct the interference by one or more of the following measures:

- Reorient or relocate the receiving antenna.
- Increase the separation between the equipment and receiver.
- Connect the equipment into an outlet on a circuit different from that to which the receiver is connected.
- Consult the dealer or an experienced radio/TV technician for help.

To satisfy FCC / IC RF exposure requirements, a separation distance of 20cm or more should be maintained between the antenna of this device and persons during device operation.

To ensure compliance, operations at closer than this distance is not recommended.

**CAUTION:** Changes or modifications not expressly approved by the party responsible for compliance could void the user's authority to operate the equipment.

Always ensure that after charging, the charging cable is wrapped around the Wall Connector.

Regularly inspect the Wall Connector and charging cable for signs of damage. If damage is found, contact ATG e-Power.

The Wall Connector contains no user-serviceable components. If the unit is not operating correctly, contact ATG e-Power.

Wipe the outside of the wall Connector, the charging cable, and the connector end of the charging cable with a clean dry cloth to remove any accumulation of dust and dirt.

 **WARNING:** Turn off input power at the circuit breaker before cleaning the Wall Connector.

 **WARNING:** Do not use cleaning solvents, scouring, powder, or any type of abrasive pad to clean the wall connector, its charging cable, or the vehicle's charging port.

 **CAUTION:** To reduce the risk of electrical shock or equipment damage, do not allow liquid to enter the wall Connector while cleaning it.

Need more assistance?

Contact ATG e-Power Customer Service:

+1-951-245-6222

[service@atgelectronics.com](mailto:service@atgelectronics.com)